



maxema[®]

CATALOGUE 2024



Made
in Italy



Prodotto
in Italia



Fabriqué
en Italie



Fabricado
en Italia

Contents

Indice

More than plastic.

07

Turn words into action

Trasformare le parole in azione. 09

RECYCLED COLLECTION 12

Maxema R-PET 14

Kind 24

retractable / meccanismo a scatto

K1 – MATT CB RP 26

K1 – MATT RP 28

K1 – GOM MATT CB RP 30

K1 – GOM MATT RP 32

K1 – FROST RP 34

Maxema Post-consumer Recycled 38

Icon Pure – Post-consumer Recycled 44

twist-action / meccanismo a rotazione

IC8 – MATT RE 46

Flow Pure – Post-consumer Recycled 48

twist-action / meccanismo a rotazione

F2P – MATT CB RE 50

F2P – MATT RE 52

Dot – Post-consumer Recycled 54

retractable / meccanismo a scatto

D1 – MATT CB RE 56

D1 – MATT RE 58

Zink – Post-consumer Recycled 60

twist-action / meccanismo a rotazione

Z1 – CB RE 62

Z1 – C RE 64

Pixel – Post-consumer Recycled 66

retractable / meccanismo a scatto

PX40 – MATT CB RE 68

PX40 – MATT RE 70

Bay – Post-consumer Recycled 72

twist-action / meccanismo a rotazione

B500 – MATT RE 74

Maxema Post-consumer Recycled Antibacterial Pens 76

Tag Green Antibacterial 82

twist-action / meccanismo a rotazione

TA2 – C AB RE 84

Icon Green Antibacterial 86

twist-action / meccanismo a rotazione

IG2 – C AB RE 88

Mood Metal 92

retractable / meccanismo a scatto

MD1 – M M1 94

MD1 – M M4 96

MD1 – M M2 98

Mood 100

retractable / meccanismo a scatto

MD1 – C M1 102

MD1 – GOM CB M1 104

MD1 – GOM C M1 106

MD1 – GOM 30 M1 108

MD1 – C M2 110

MD1 – C M3 111

Icon Pure 112

twist-action / meccanismo a rotazione

IC8 – GOM 114

Flow Pure 116

twist-action / meccanismo a rotazione

F2P – GOM MATT 118

F2P – MATT CB 120

F2P – MATT 122

F2P – MATT F 124

F2P – C 126

F2P – GOM K 128

F2P – GOM CB 130

F2P – GOM 30 132

F2P – GOM CF 134

F2P – GOM KF 135

F2P – GOM 30 F 136

Flow 138

twist-action / meccanismo a rotazione

F1 – MATT AL 140

F1 – C CR 142

F1T – GOM C CR 144

F1T – GOM CB CR 146

F1T – GOM 30 CR 148

Dot 150

retractable / meccanismo a scatto

D1 – MATT B 152

D1 – MATT CB 154

D1 – MATT 156

D1 – MATT K 158

D1 – MATT F 160

D1 – B CR 162

D1 – CB CR 164

D1 – C CR 166

D1 – 30 CR 168

D1 – GOM K 170

D1 – GOM CB CR 172

D1 – GOM C CR 174

D1 – GOM 30 CR 176

D1 – C GOLD 178

D1 – GOM KF CR 179

Zink 180

twist-action / meccanismo a rotazione

Z1 – CB 182

Z1 – C 184

Z1 – 30 186

Z1 – CF 188

View 190

twist-action / meccanismo a rotazione

V1 – C CR / V1 – C CR T 192

V1 – 30 CR / V1 – 30 CR T 194

V1 – AL CR / V1 – AL CR T 195

V1 – GOM C CR / 196

V1 – GOM C CR T 196

Tag 198

twist-action / meccanismo a rotazione

TA1 – MATT AL B 200

TA1 – B CR 202

TA1 – C CR 204

TA1 – MET AL 206

TA1 – AL CR 207

Icon 208

twist-action / meccanismo a rotazione

IC400 – MATT 210

IC400 – FROST 211

IC400 – MATT AL 212

IC400 – C CR 214

IC400 – FROST AL 216

IC400 – 30 CR 217

IC400 – C GOLD 218

IC400 – MET AL 219

IC400 – AL CR 219

Ethic 220

twist-action / meccanismo a rotazione

ET900 – MULTICOLOUR 222

ET900 – FLAG 223

ET900 – C FLAG 223

ET900 – B 224

ET900 – BC 225

ET900 – C CR 226

ET900 – C GOLD 227

ET900 – AL 228

ET900 – AL CR 229

ET900 – AL FLAG 229

ET900 – MET CR 230

ET900 – MET AL 231

Next 232

retractable / meccanismo a scatto

NX400 – C CR 234

NX400 – 30 CR 235

Pixel 236

retractable / meccanismo a scatto

PX40 – MATT CB 238

PX40 – MATT CR 240

PX40 – B 242

PX40 – C 243

PX40 – 30 244

PX40 – FROST NEUTRAL 245

PX40 – FROST 246

PX40 – GOM C CR 248

PX40 – GOM 30 CR 249

Bay 250

twist-action / meccanismo a rotazione

B500 – MATT BC 252

B500 – MATT 254

B500 – BC 256

B500 – C 257

B500 – 30 258

B500 – FROST 259

Maxema Antibacterial Pens 260

Dot – Antibacterial 266

retractable / meccanismo a scatto

D1 – MATT CB AB 266

Flow Pure – Antibacterial 268

twist-action / meccanismo a rotazione

F2P – C AB 268

Zink – Antibacterial 269

twist-action / meccanismo a rotazione

Z1 – C AB 269

Pixel – Antibacterial 270

retractable / meccanismo a scatto

PX40 – MATT CB AB 270

Bay – Antibacterial 271

twist-action / meccanismo a rotazione

B500 – C AB 271

Tag green 272

twist-action / meccanismo a rotazione

TA2 – B 276

TA2 – BC 277

Icon green 278

twist-action / meccanismo a rotazione

IG2 – BC 282

IG2 – C 283

Technical information 285

informazioni tecniche

Packaging 308

Sales support 314

supporti di vendita

Inks and refills 322

inchiostri e refill

Finishes 324

finiture

Colour palette 326

palette colori

More than plastic.

EN

Those who know us are well aware that our pens are much more than just plastic. For more than two generations, we have worked with a close-knit team of trusted people in Italy, crafting exceptional writing instruments with passion and dedication.

Every Maxema pen is created to take care of the environment and our customers with safe, reliable and durable materials. Our mission is to support your projects and help you, wherever you are in the world, to tell your story and deliver a lasting message.

IT

Chi ci conosce lo sa bene, le nostre penne sono molto più che semplice plastica. Da oltre due generazioni lavoriamo in Italia con un team di persone fidate e affiatate, con le quali amiamo creare strumenti di scrittura di altissima qualità.

Ogni penna Maxema nasce per prenderci cura dell'ambiente e dei nostri clienti, con materiali sicuri, affidabili e duraturi. La nostra missione è quella di sostenere i tuoi progetti e aiutarti, in qualsiasi parte del mondo, a raccontare la tua storia lasciando un messaggio che duri nel tempo.



TURN WORDS INTO ACTION.

Trasformare le parole in azione.



EN

Our company is ClimatePartner certified. To deliver our commitment in transparent fashion, we have calculated Maxema's corporate carbon footprint and defined new targets and ways to help reduce it. We know, however, that there will always be emissions that we cannot avoid or reduce. To offset these, we have chosen to fund a climate protection initiative in association with the Plastic Bank project, an organisation that provides a stable income for groups of people who commit to removing plastic from coast-lines and oceans. The material collected is then turned into raw material for re-use in other products and packaging, so contributing to the circular economy.

IT

La nostra azienda è certificata ClimatePartner. Per comunicare in modo trasparente il nostro impegno abbiamo calcolato l'impronta di carbonio aziendale di Maxema e definito nuovi obiettivi e modalità per contribuire a ridurla. Sappiamo, però, che ci saranno sempre delle emissioni che non potremo evitare o diminuire. Per compensarle, abbiamo scelto di sostenere finanziariamente un progetto di protezione del clima abbinato al progetto Plastic Bank, un'organizzazione che permette un reddito stabile a gruppi di persone che si impegnano ad eliminare la plastica dalle coste e dagli oceani. Il materiale raccolto viene poi trasformato in materia prima per essere riutilizzato in altri prodotti e imballaggi, contribuendo all'economia circolare.

BEING ECO FRIENDLY IS A WAY OF LIFE.

Essere eco-sostenibili è uno stile di vita.



EN

Change starts with our choices. In cooperation with the Alperia Group, we only use energy from renewable sources, namely hydroelectric power stations in South Tyrol. Moreover, our plan to re-use scrap enables us to limit in-house production wastage. And to deliver our products and our message in support of the planet everywhere, we opt to use packaging made from recycled, eco-friendly materials.

IT

Il cambiamento inizia dalle nostre scelte. In collaborazione con Alperia Group, usiamo solo energia proveniente da fonti rinnovabili, per la precisione da centrali idroelettriche dell'Alto Adige. Inoltre, grazie ad un piano di riutilizzo del materiale di scarto, limitiamo gli sprechi di produzione interni all'azienda. E per portare ovunque i nostri prodotti e il nostro messaggio a sostegno del pianeta, prediligiamo l'impiego di packaging e imballaggi realizzati con materiali riciclati ed ecosostenibili.

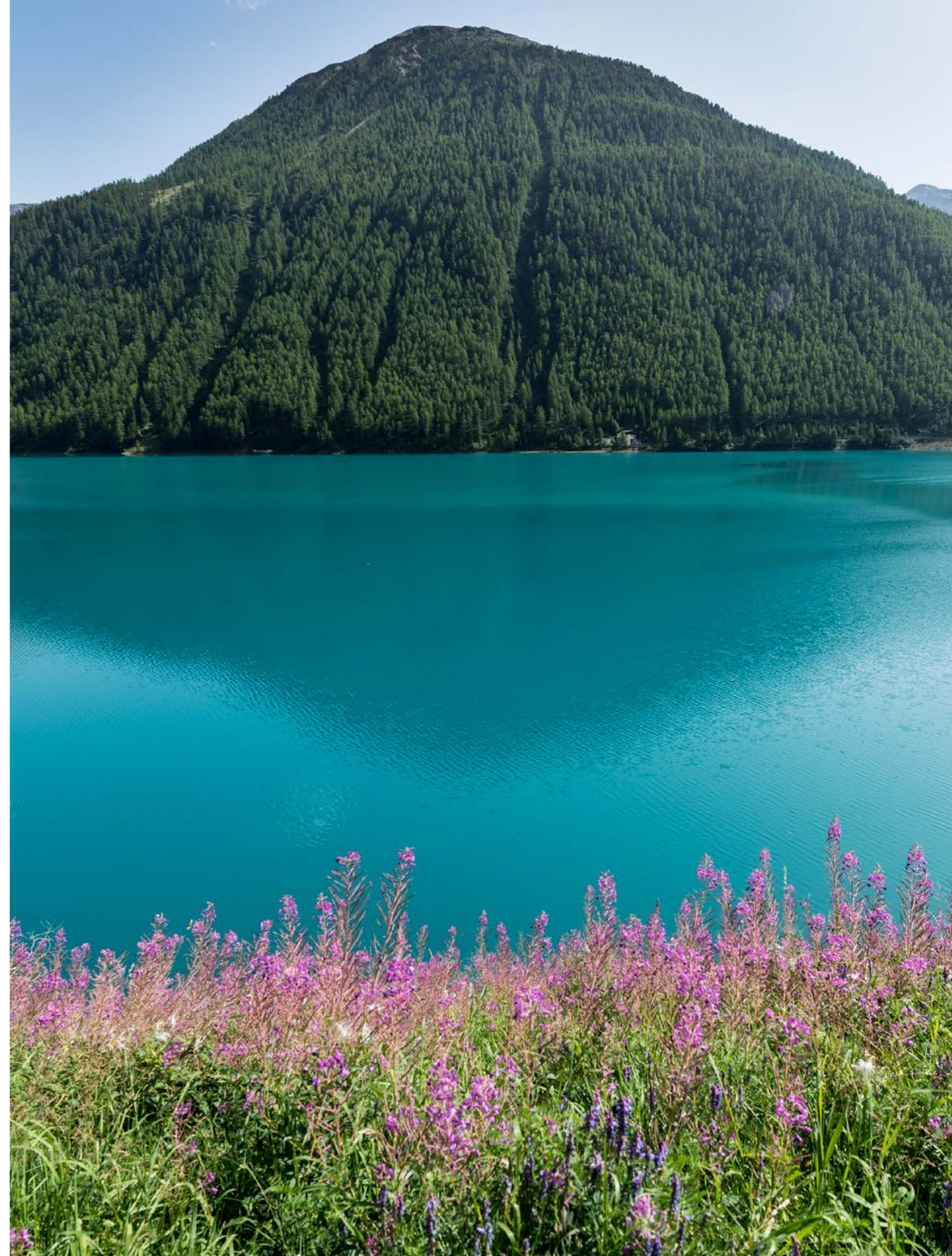

RECYCLED COLLECTION





RECYCLED PET PENS

A new circular story has emerged out of one of the commonest and most ubiquitous objects of our daily life. A new model to write change together, with kindness and care for the planet.

—
Da uno degli oggetti più comuni e presenti nelle nostre giornate nasce una nuova storia circolare. Un nuovo modello per scrivere il cambiamento insieme, con gentilezza e attenzione verso il pianeta.

A NEW KIND OF PEN.

R-PET

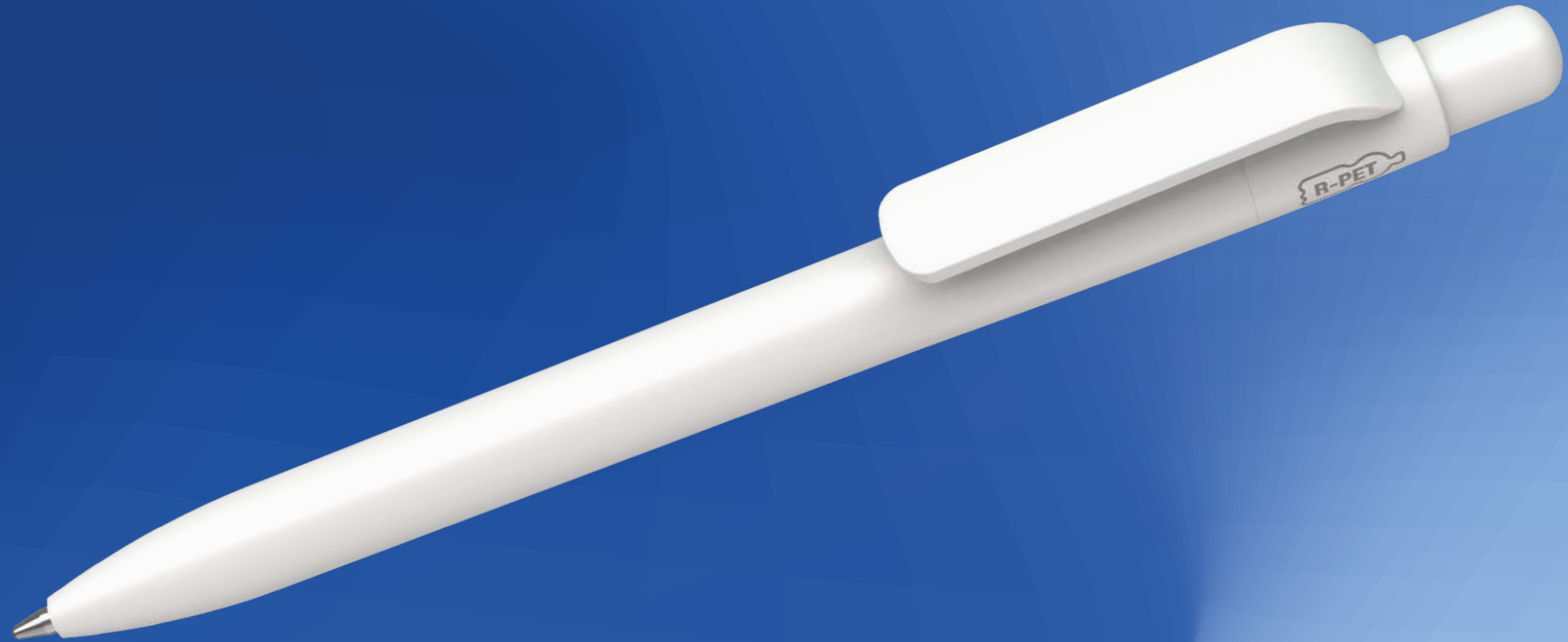

EN

Graceful lines, an iconic profile and plenty of room for customisation. Kind is our new recyclable and refillable model in R-PET. Delivering a message with a strong visual impact and low environmental impact.

IT

Linee morbide, profilo iconico e ampio spazio di personalizzazione. Kind è il nostro nuovo modello in R-PET, riciclabile e ricaricabile. Per trasmettere un messaggio con un forte impatto visivo e un basso impatto ambientale.

Scan the QR Code and be Kind
Scannerizza il QR Code e be Kind



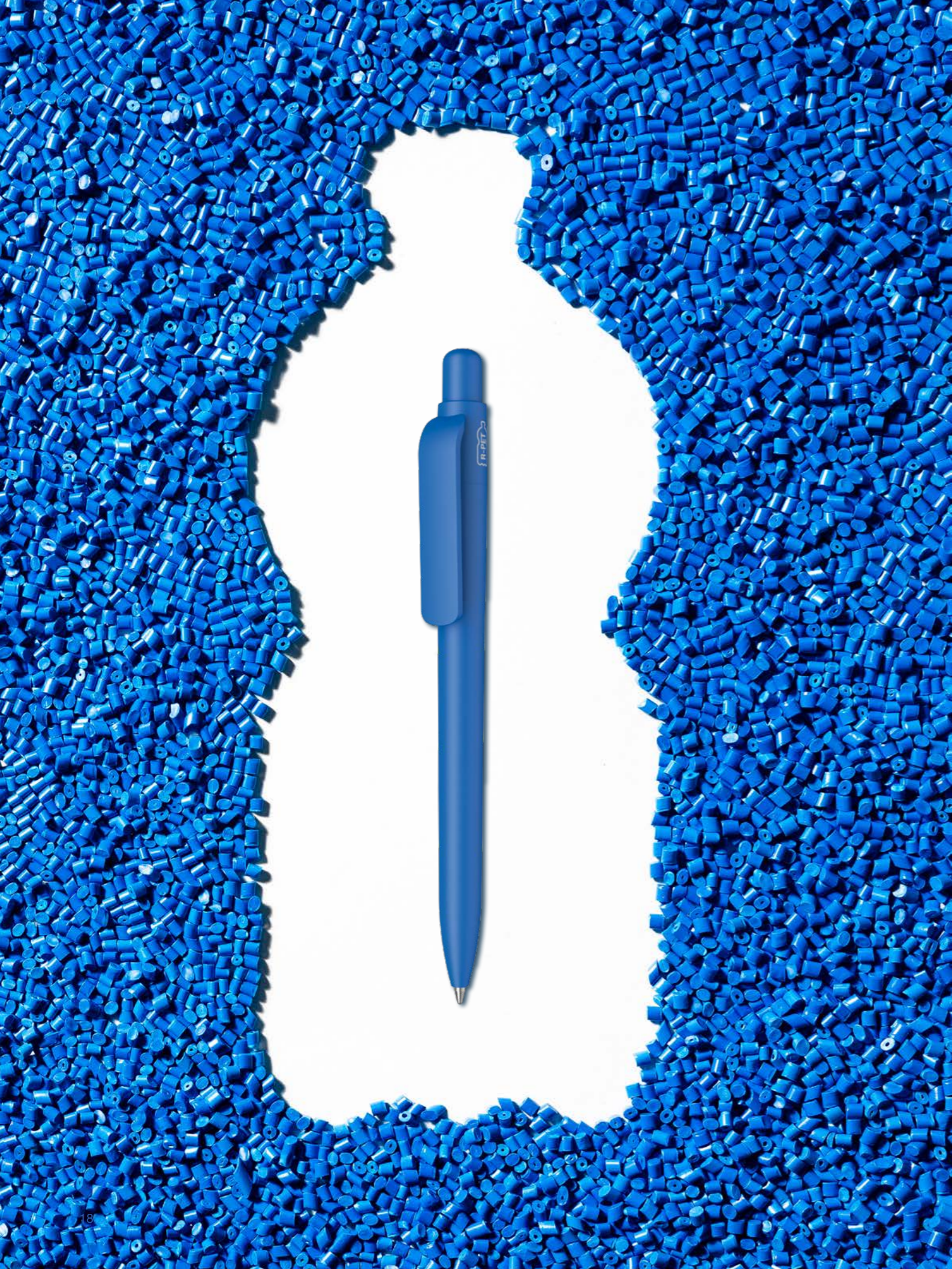

MESSAGE FROM A BOTTLE.

Messaggio da una bottiglia.

EN

Kind is made of certified R-PET. This material is obtained by gathering and recycling PET, the most commonly used polyester in the production of soft-drink bottles. R-PET is made of recycled plastic and contributes to reducing the environmental footprint. Studies show that, apart from combating the accumulation of plastic waste, recycling 1kg of R-PET is equivalent to reducing CO₂ emissions by 3kg.

IT

Kind è realizzata con R-PET certificato. Questo materiale è ottenuto attraverso un processo di recupero e riciclo del PET, il poliestere più comune nella produzione di bottiglie per bevande. L'R-PET è composto da plastica riciclata e contribuisce a ridurre l'impatto ambientale. Gli studi dimostrano che riciclare 1kg di R-PET, oltre a diminuire l'accumulo di rifiuti plastici, equivale a ridurre di 3 kg le emissioni di CO₂.

CLEAN THE PLANET, COLOUR YOUR WORLD.

Pulisci il pianeta, colora il tuo mondo.

EN

23 colours available to enhance your message.

IT

23 colori disponibili per valorizzare il tuo messaggio.



DISCOVER EVERY KIND OF FINISH

Scopri ogni tipo di finitura.



MATT

GOM MATT

FROST

EN

Matt, rubberised or frost, choose from 3 finishes and 5 combinations.

IT

Matt, gommata o frost, scegli tra 3 finiture e 5 combinazioni.

KIND

△ RECYCLED PET

Message from a bottle.
Messaggio da una bottiglia.

Created to
write change.

*Realizzata per scrivere
il cambiamento.*



Technical information at p. 287
Informazioni tecniche a pag. 287

K1 MATT CB RP

Solid colour barrel with matt finish, solid matt white colour clip and push-button

White clip: ideal for multicolour brands.

18 orange / pad printing 32 x 7 mm
18 arancio / tampografia 32 x 7 mm

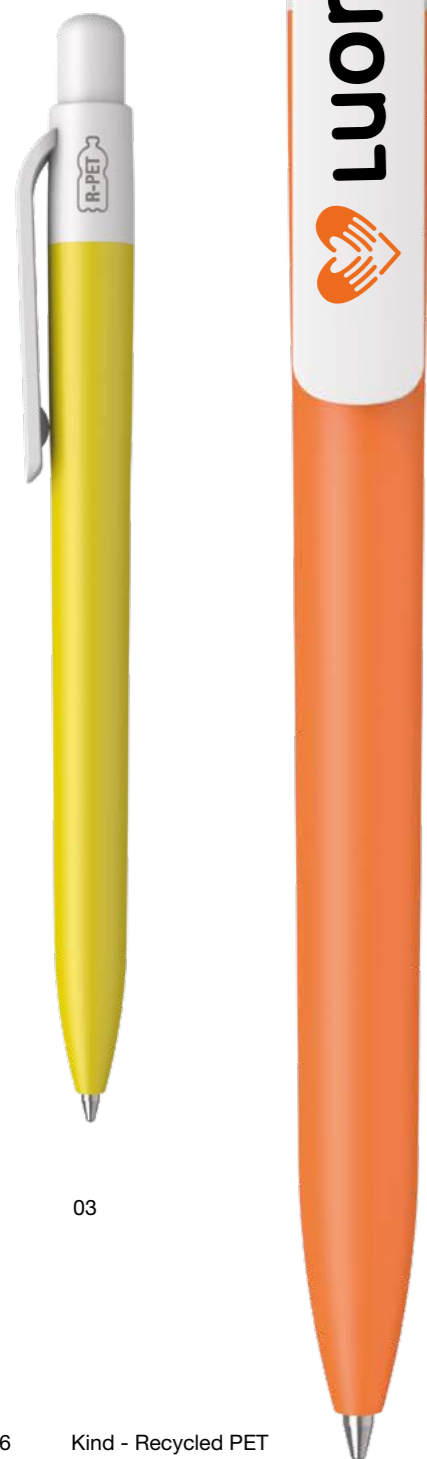

03



15



79

09 green / pad printing 32 x 7 mm
09 verde / tampografia 32 x 7 mm



K1 MATT CB RP

Fusto in colore coprente con finitura satinata, clip e tappino in colore bianco coprente satinato

Clip bianca: ideale per i brand a più colori.



75



77



12

22 blue / pad printing 32 x 7 mm
22 blu / tampografia 32 x 7 mm



05



04

K1 | MATT RP

Solid colours with matt finish

Strong visual impact, low environmental impact.

15 red / pad printing 32 x 7 mm
15 rosso / tampografia 32 x 7 mm



03



18



79



09

01 white / pad printing 32 x 7 mm
01 bianco / tampografia 32 x 7 mm

K1 | MATT RP

Colori coprenti con finitura satinata

Alto impatto visivo, basso impatto ambientale.



77



12



22



05



04

75 dark green / pad printing 32 x 7 mm
75 verde scuro / tampografia 32 x 7 mm

K1 | GOM MATT CB RP

Solid colour barrel with rubber finish,
solid white colour clip and push button

Soft touch,
safe grip.



03

18

15

09

79 lime / pad printing 32 x 7 mm
tampografia 32 x 7 mm

K1 | GOM MATT CB RP

*Fusto in colore coprente gommato,
clip e tappino in colore bianco
coprente satinato*

Morbida al tatto,
grip perfetto.



77 cyan / pad printing 32 x 7 mm
77 ciano / tampografia 32 x 7 mm

75

12

22

05

04 black / pad printing 32 x 7 mm
04 nero / tampografia 32 x 7 mm

K1 | GOM MATT RP

solid colour barrel with rubber finish,
solid colour clip and push button with
matt finish

Design
highlighted in the
monochrome
version.

18 orange / pad printing 32 x 7 mm
18 arancio / tampografia 32 x 7 mm



09 green / pad printing 32 x 7 mm
09 verde / tampografia 32 x 7 mm

K1 | GOM MATT RP

Fusto in colore coprente gommato,
tappino e clip in colore coprente
satinato

Design in evidenza
con la versione
monocromatica.



12 light blue / pad printing 32 x 7 mm
12 azzurro / tampografia 32 x 7 mm

K1 FROST RP

Transparent colours
with matt finish

Transparent
is cool!



39



52 yellow / pad printing 32 x 7 mm
52 giallo / tampografia 32 x 7 mm

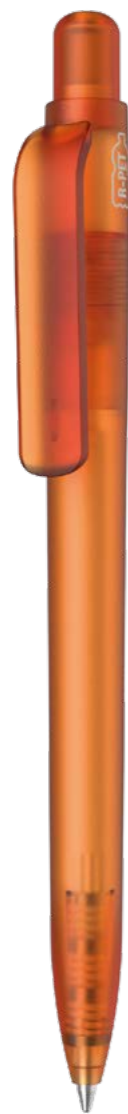

53



45



55

K1 FROST RP

Colori trasparenti
con finitura satinata

Trasparente
è cool!



78



49 green / pad printing 32 x 7 mm
49 verde / tampografia 32 x 7 mm



67



44



32

50 dark grey / pad printing 32 x 7 mm
50 grigio scuro / tampografia 32 x 7 mm



A CIRCULAR STORY.

Una storia circolare.

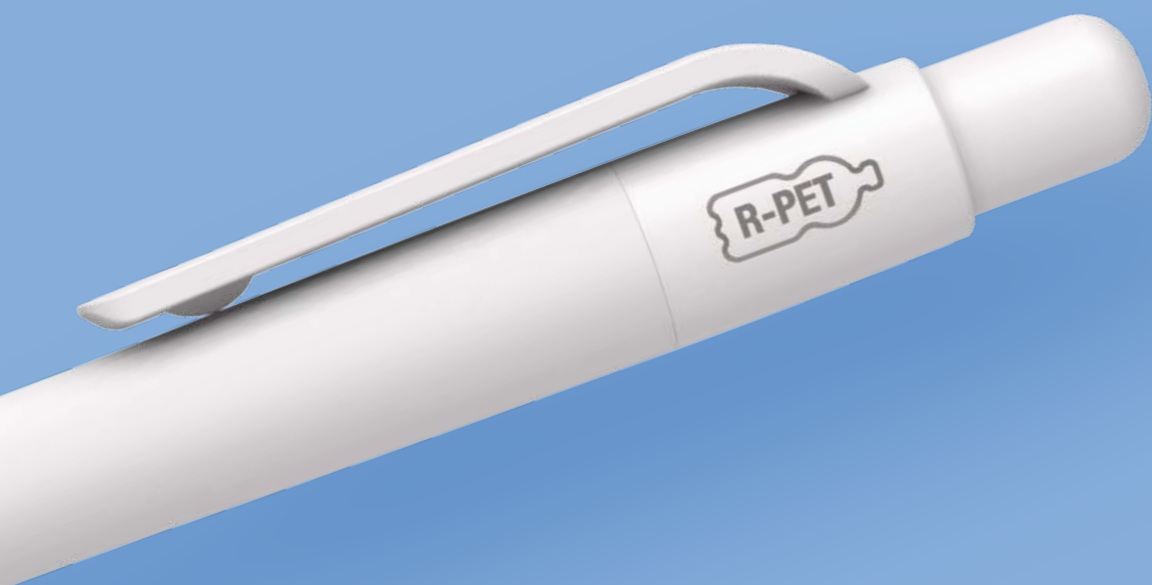

EN

Kind is made not only of recycled materials but of recyclable ones too. To continue writing change even when the pen runs out, separate the plastic components from the metals and dispose of them in the relevant recycling bin. You can deposit the refill in the unsorted collection.

IT

Kind è composta da materiali non solo riciclati ma anche riciclabili. Per continuare a scrivere il cambiamento anche quando la penna si scarica, separa i componenti di plastica dai metalli e smaltiscili nelle relative tipologie di raccolta differenziata. Il refill puoi depositarlo nella raccolta indifferenziata.

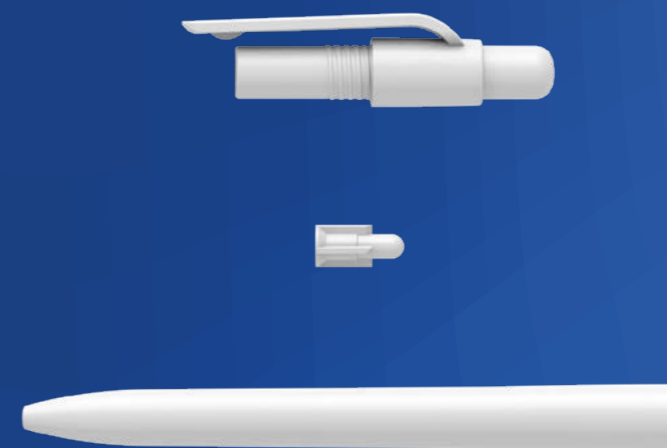

RECYCLABLE PLASTIC ELEMENTS
ELEMENTI IN PLASTICA RICICLABILE



SPRINGS / METAL
MOLLE / METALLI



REFILL / UNSORTED
REFILL / INDIFFERENZIATO



POST-CONSUMER RECYCLED PENS

Change is a choice and it depends on each of us. To change means to choose responsible, sustainable consumption that prefers quality to quantity, better still if the raw materials come from recovery chains.

—
Il cambiamento è una scelta e dipende da ognuno di noi. Cambiare significa scegliere un consumo responsabile e sostenibile che predilige la qualità, meglio se con l'impiego di materie prime provenienti da filiere di recupero.

Scegli un prodotto che dura nel tempo.

CHOOSE BETTER. MAKE IT LAST.

EN

Who said good things don't last? At Maxema, we do everything we can to make our pens live for as long as possible. A Maxema pen loves nature: the longer it lasts, the less it pollutes. And, since one life seemed too short for us, we have created a line in post-consumer recycled plastic, beautiful to look at and even more environmentally friendly. All our pens can be made of recycled plastic: choose your favourite model, inspired by the colours of Nature.

IT

Chi l'ha detto che le cose belle durano poco? Noi di Maxema ce la mettiamo tutta per far vivere le nostre penne il più a lungo possibile. Una penna Maxema ama la natura: più tempo dura, meno inquina. E, visto che una vita sola ci sembrava troppo breve, abbiamo realizzato una linea in plastica riciclata post-consumo, bella da vedere e ancora più attenta all'ambiente. Tutte le nostre penne possono essere realizzate in plastica riciclata post-consumo: scegli il tuo modello preferito, ispirato ai colori della natura.



Una vita sola non basta.

ONE LIFE IS TOO SHORT.

EN

Why use plastic only once when it can be turned into something new?

For our post-consumer recycled plastic pens we use materials of European origin that are 100% derived from post-consumer products. When appropriately treated, these guarantee high quality plastics, certified and compliant with RoHS and REACH regulations.

IT









Perché usare la plastica una volta sola quando può trasformarsi in qualcosa di nuovo?

Per le nostre penne in plastica riciclata usiamo materiali di origine europea derivanti al 100% da prodotti post-consumo che, opportunamente trattati, garantiscono materie plastiche di elevata qualità, certificate e conformi alle normative RoHS e REACH.

La Terra è piena di sfumature.

THE EARTH IS FULL OF COLOURS.

solid / coprenti

06		ICE	10		CLOUD
76		DESERT	87		MUD
19		FOREST	21		ABYSS
58		GRAPHITE	07		ONYX

Icon Pure

△ POST-CONSUMER RECYCLED

The purity of simplicity.
La purezza della semplicità.

All-round personality.
Personalità a tutto tondo.

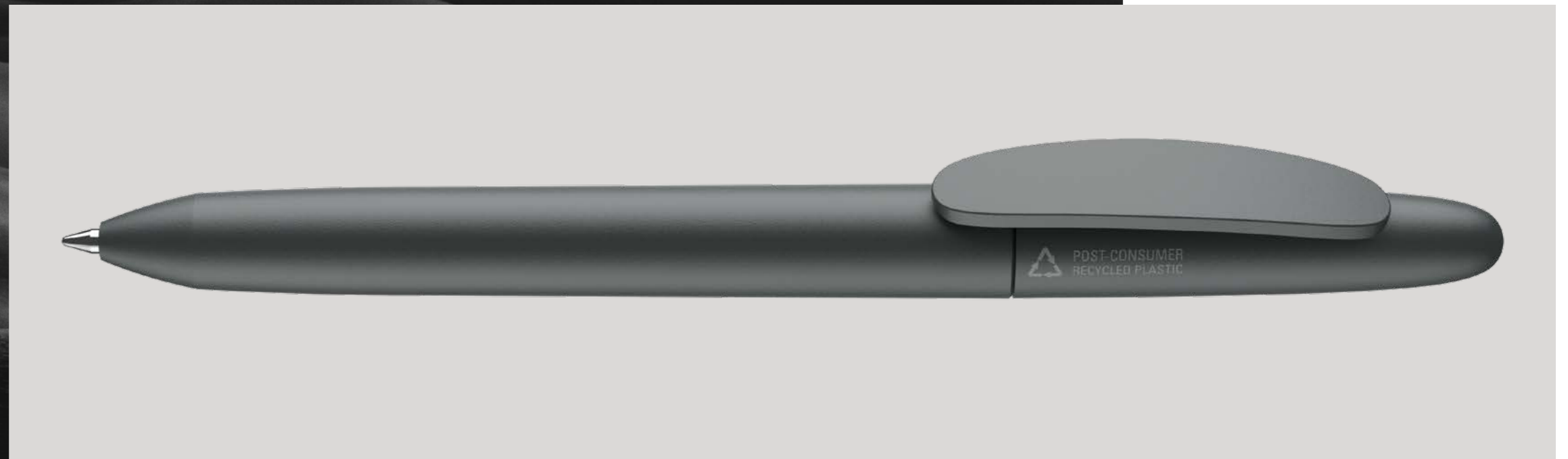

QUALITY NOT QUANTITY

The entire Maxema collection is available in post-consumer recycled plastic on request /
Tutta la collezione Maxema è realizzabile in plastica riciclata post-consumo su richiesta

Technical information at p. 292
Informazioni tecniche a pag. 292

Post-consumer recycled plastic
Solid colours with matt finish

Design embraces
sustainability.



06

10

76

87 mud / pad printing 35 x 7 mm
tampografia 35 x 7 mm

Plastica riciclata post-consumo
Colori coprenti con finitura satinata

Il design abbraccia
la sostenibilità.



19

21

58

07 onyx / pad printing 35 x 7 mm
tampografia 35 x 7 mm



MY BOX RECYCLED

Universal reclosable single pen box
in recycled Fedrigoni paper.
Info at p. 312

*Astuccio universale richiudibile per penna
singola in cartoncino riciclato Fedrigoni.
Info pag. 312*

Flow Pure

△ POST-CONSUMER RECYCLED

Free from extra.
Pura ed essenziale.

The essence of design.
L'essenza del design.



QUALITY NOT QUANTITY

The entire Maxema collection is available in post-consumer recycled plastic on request /
Tutta la collezione Maxema è realizzabile in plastica riciclata post-consumo su richiesta

Technical information at p. 293
Informazioni tecniche a pag. 293

Post-consumer recycled plastic
Solid colour barrel and cap, solid white
colour clip, matt finish



10



76



87 mud / pad printing 40 x 9 mm
tampografia 40 x 9 mm



19



21



58



07 onyx / pad printing 40 x 9 mm
tampografia 40 x 9 mm

Plastica riciclata post-consumo
Fusto e cappuccio in colore coprente,
clip in colore bianco coprente,
finitura satinata



MY BOX RECYCLED

Universal reclosable single pen box
in recycled Fedrigoni paper.
Info at p. 312

*Astuccio universale richiudibile per penna
singola in cartoncino riciclato Fedrigoni.
Info pag. 312*

Post-consumer recycled plastic
Solid colours with matt finish

For responsible
consumption:
more quality, less
quantity.

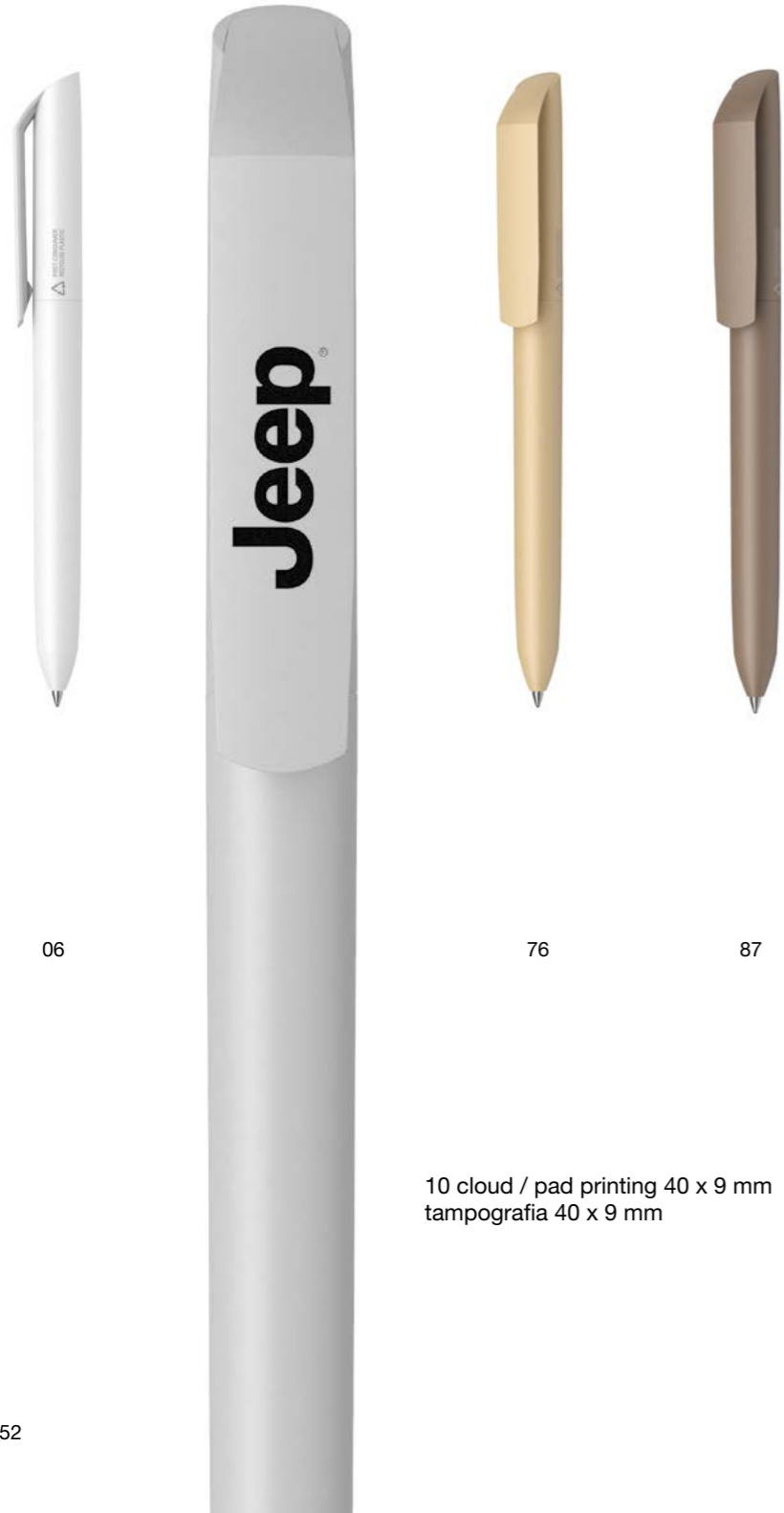

06

Jeep

76

87

10 cloud / pad printing 40 x 9 mm
tampografia 40 x 9 mm

Plastica riciclata post-consumo
Colori coprenti con finitura satinata

Per un consumo
responsabile: più
qualità, meno
quantità.

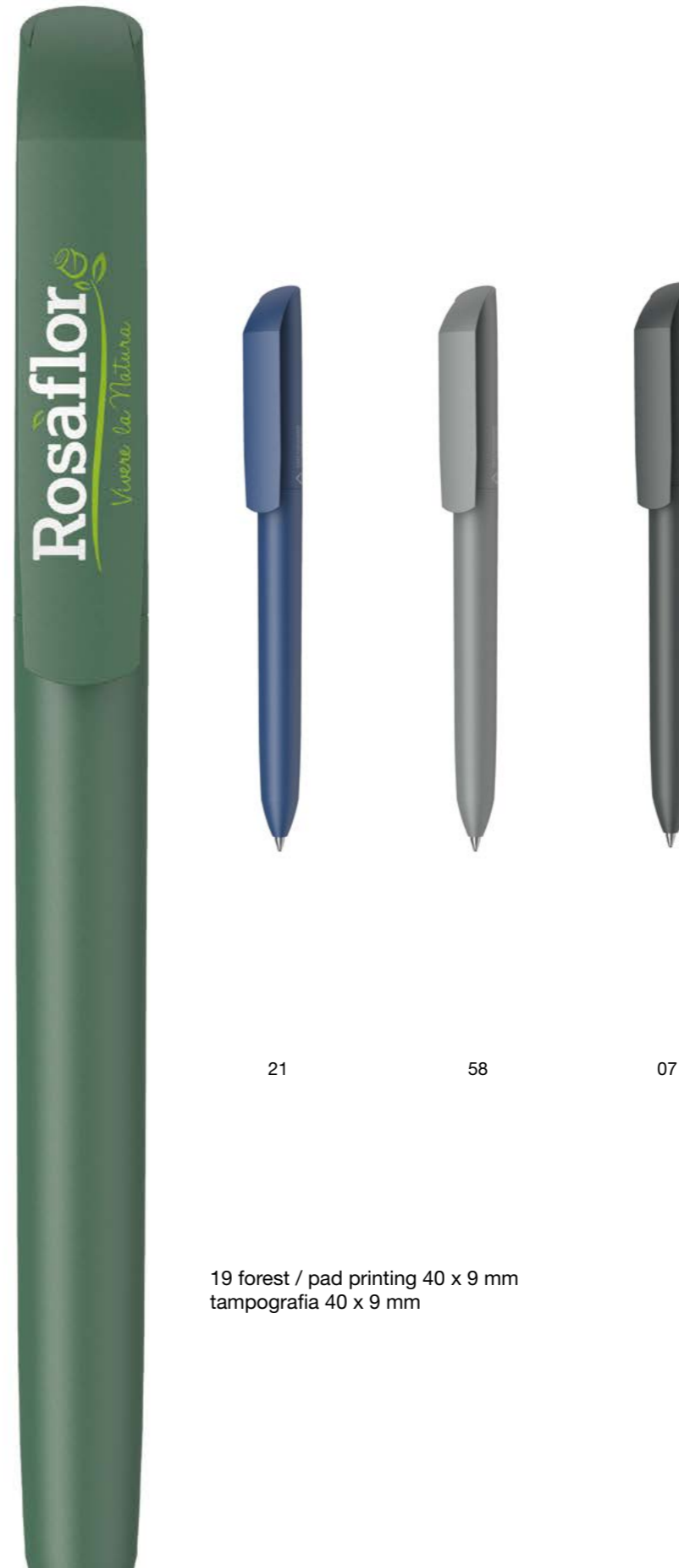

Rosafior
Vivere la Natura

21

58

07

19 forest / pad printing 40 x 9 mm
tampografia 40 x 9 mm

Dot

△ POST-CONSUMER RECYCLED

Different from the rest, full stop.
Diversa da tutte, punto.

A pen that reveals its originality in its details.

È nei dettagli che rivela la sua originalità.

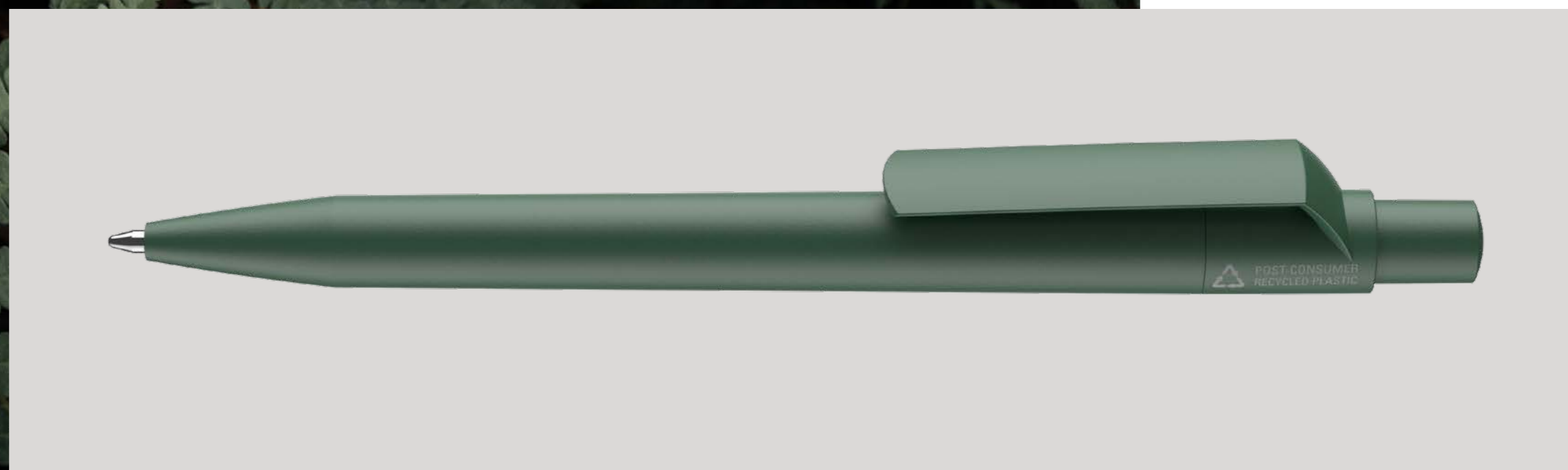

QUALITY NOT QUANTITY

The entire Maxema collection is available in post-consumer recycled plastic on request /
Tutta la collezione Maxema è realizzabile in plastica riciclata post-consumo su richiesta

Technical information at p. 295
Informazioni tecniche a pag. 295

D1 MATT CB RE

Post-consumer recycled plastic
Solid colour barrel with matt finish,
solid matt white clip and push-button,
solid glossy white little sphere



10



76



87



MY BOX RECYCLED

Universal reclosable single pen box
in recycled Fedrigoni paper.
Info at p. 312

*Astuccio universale richiudibile per penna
singola in cartoncino riciclato Fedrigoni.
Info pag. 312*



19



58



07

21 abyss / pad printing 40 x 9 mm
tampografia 40 x 9 mm

Plastica riciclata post-consumo
Fusto in colore coprente con finitura
satinata, clip e tappino in colore
bianco coprente satinato, piccola
sfera in colore bianco coprente lucido

Post-consumer recycled plastic
Solid colours with matt finish,
solid glossy colour little sphere

The beauty
of sustainability:
8 colour
shades inspired
by nature.



06 ice / pad printing 40 x 9 mm
tampografia 40 x 9 mm

Plastica riciclata post-consumo
Colori coprenti con finitura satinata,
piccola sfera in colore coprente lucido

La bellezza
della sostenibilità:
8 sfumature
di colore ispirate
alla natura.



58 graphite / pad printing 40 x 9 mm
tampografia 40 x 9 mm

Zink

△ POST-CONSUMER RECYCLED

Solid geometries.
Solide geometrie.

A pen with a clean-cut
profile and strong
personality.

*Una penna dal profilo
tagliante e dal carattere
deciso.*



QUALITY NOT QUANTITY

The entire Maxema collection is available in post-consumer recycled plastic on request /
Tutta la collezione Maxema è realizzabile in plastica riciclata post-consumo su richiesta

Technical information at p. 296
Informazioni tecniche a pag. 296

Post-consumer recycled plastic
Solid colours barrel, solid white
colour cap, glossy finishes

Elegance and
environmental
friendliness:
uncompromisingly
together.



10



76



87



19



21 abyss / pad printing 43 x 9 mm
tampografia 43 x 9 mm



58



07

Plastica riciclata post-consumo
Fusto in colori coprenti, cappuccio in
colore bianco coprente, finiture lucide

Eleganza e
attenzione per
l'ambiente: insieme
senza compromessi.



06



10 cloud / pad printing 43 x 9 mm
tampografia 43 x 9 mm



76



87

Post-consumer recycled plastic
Solid colours with glossy finish



MY BOX RECYCLED

Universal reclosable single pen box
in recycled Fedrigoni paper.
Info at p. 312

*Astuccio universale richiudibile per penna
singola in cartoncino riciclato Fedrigoni.
Info pag. 312*



19



21



58

07 onyx / pad printing 43 x 9 mm
tampografia 43 x 9 mm



Plastica riciclata post-consumo
Colori coprenti con finitura lucida

Pixel

△ POST-CONSUMER RECYCLED

High resolution design.
Il design ad alta definizione.

A synthesis
of contemporary style.

*Sintesi dello stile
contemporaneo.*



QUALITY NOT QUANTITY

The entire Maxema collection is available in post-consumer recycled plastic on request /
Tutta la collezione Maxema è realizzabile in plastica riciclata post-consumo su richiesta

Technical information at p. 304
Informazioni tecniche a pag. 304

PX40 | MATT CB RE

Post-consumer recycled plastic
Solid colour barrel with matt finish,
solid glossy white colour clip
and push-button



10



76 desert / pad printing 30 x 8 mm
tampografia 30 x 8 mm



87



19



21



58 graphite / pad printing 30 x 8 mm
tampografia 30 x 8 mm



07

Plastica riciclata post-consumo
Fusto in colore coprente con finitura
satinata, clip e tappino in colore
bianco coprente con finitura lucida



MY BOX RECYCLED

Universal reclosable single pen box
in recycled Fedrigoni paper.
Info at p. 312

*Astuccio universale richiudibile per penna
singola in cartoncino riciclato Fedrigoni.
Info pag. 312*

PX40 | MATT RE

Post-consumer recycled plastic
Solid colour barrel with matt finish,
solid glossy colour clip and push-button

Guaranteed
and certified
post-consumer
recycled plastic
of European origin.



*Plastica riciclata post-consumo
Fusto in colore coprente
con finitura satinata, clip e tappino
in colore coprente con finitura lucida*

Plastica riciclata
post-consumo
di provenienza
europea, garantita
e certificata.



19 forest / pad printing 30 x 8 mm
tampografia 30 x 8 mm

Bay

△ POST-CONSUMER RECYCLED

Casual and attractive.
Disinvolta e accattivante.

Draws attention
for its simplicity.

*Attrae per
la sua semplicità.*

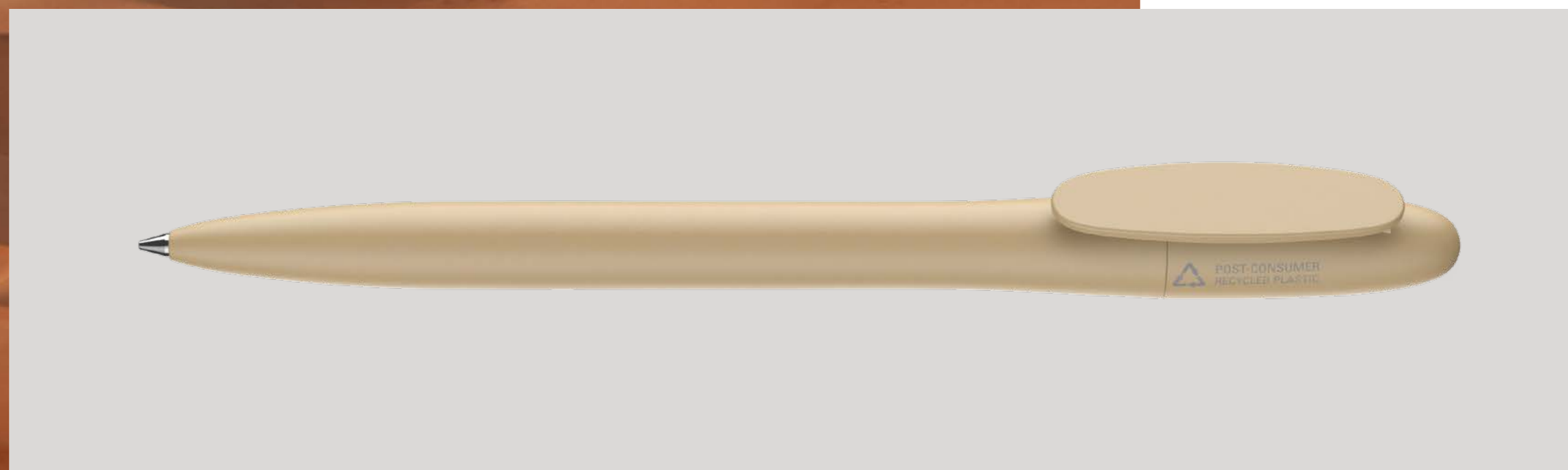

QUALITY NOT QUANTITY

The entire Maxema collection is available in post-consumer recycled plastic on request /
Tutta la collezione Maxema è realizzabile in plastica riciclata post-consumo su richiesta

Technical information at p. 305
Informazioni tecniche a pag. 305

Post-consumer recycled plastic
Solid colours with matt finish

Change is a
choice and it
depends on
each of us.



06

10

76

87



19

21

07

58 graphite / pad printing 30 x 7 mm
tampografia 30 x 7 mm

Plastica riciclata post-consumo
Colori coprenti con finitura satinata

Il cambiamento
è una scelta
e dipende
da ognuno di noi.



MY BOX RECYCLED

Universal reclosable single pen box
in recycled Fedrigoni paper.
Info at p. 312

*Astuccio universale richiudibile per penna
singola in cartoncino riciclato Fedrigoni.
Info pag. 312*



POST-CONSUMER RECYCLED
ANTIBACTERIAL PENS

Safety meets sustainability:
discover our antibacterial
pens in post-consumer
recycled plastic with the
Jumbo refill designed to last
even longer.

—
*La sicurezza incontra
la sostenibilità: scopri le
nostre penne antibatteriche
in plastica riciclata
post-consumo, con il refill
Jumbo pensato per durare
ancora più a lungo.*

Doppia protezione,
per te e per l'ambiente

DOUBLE PROTECTION, FOR YOU AND THE ENVIRONMENT



EN

Maxema's new antibacterial pens are made from recycled plastic deriving 100% from European post-consumer products, to which a special additive is added that destroys up to 99.99% of bacteria.

IT

Le nuove penne antibatteriche Maxema sono realizzate in plastica riciclata derivante al 100% da prodotti post-consumo europei, a cui viene aggiunto uno speciale additivo che distrugge fino al 99,99% dei batteri.



Una penna sostenibile
e duratura

A SUSTAINABLE AND DURABLE PEN

EN

Recycled plastic, Jumbo refill and silver ions:
the right combination for safe living, having more ink
to write with and for saving the planet.









IT

Plastica riciclata, refill Jumbo e ioni d'argento:
la combinazione giusta per vivere in modo sicuro,
avere più inchiostro per scrivere e salvaguardare
il pianeta.

La sicurezza,
in tutte le sue sfumature

SAFETY, IN ALL ITS NUANCES

solid / coprenti

06		ICE	10		CLOUD
76		DESERT	87		MUD
19		FOREST	21		ABYSS
58		GRAPHITE	07		ONYX

Tag Green Antibacterial

△ POST-CONSUMER RECYCLED

Objective: total safety.
Obiettivo: sicurezza totale.

Design that combines safety and environment friendliness.

Il design sposa la sicurezza e rispetta l'ambiente.



The entire Maxema collection is available in post-consumer recycled plastic on request /
Tutta la collezione Maxema è realizzabile in plastica riciclata post-consumo su richiesta

Technical information at p. 300
Informazioni tecniche a pag. 300

Recycled antibacterial plastic
Solid colours with glossy finish

Recycled
and antibacterial:
the new plastic
that takes care
of you and
the environment



10 76 87

06 ice / pad printing 35 x 7 mm
tampografia 35 x 7 mm

Plastica riciclata antibatterica
Colori coprenti con finitura lucida

Riciclata
e antibatterica:
la nuova plastica
che si prende
cura di te
e dell'ambiente



19 21 58 07



MY BOX RECYCLED

Universal reclosable single pen box
in recycled Fedrigoni paper.
Info at p. 312

*Astuccio universale richiudibile per penna
singola in cartoncino riciclato Fedrigoni.
Info pag. 312*

Icon Green Antibacterial

△ RECYCLED

People and environment friendly.
Nel rispetto dell'uomo e della natura.

Testimony of an
enduring message.

*Testimone di un
messaggio destinato
a durare nel tempo.*



QUALITY NOT QUANTITY

The entire Maxema collection is available in recycled plastic on request /
Tutta la collezione Maxema è realizzabile in plastica riciclata su richiesta

Technical information at p. 301
Informazioni tecniche a pag. 301

Recycled antibacterial plastic
Solid colours with glossy finish



10 cloud / screen printing 40 x 30 mm
serigrafia 40 x 30 mm

Plastica riciclata antibatterica
Colori coprenti con finitura lucida



MY BOX RECYCLED

Universal reclosable single pen box
in recycled Fedrigoni paper.
Info at p. 312

*Astuccio universale richiudibile per penna
singola in cartoncino riciclato Fedrigoni.
Info pag. 312*



The entire Maxema collection is available in post-consumer recycled plastic on request.*

—
*Tutta la collezione Maxema è realizzabile in plastica riciclata post-consumo su richiesta.**

*On orders over 10,000 units. / Per ordini superiori alle 10.000 unità.

Mood Metal

Design with a metal touch.
Il design incontra il metallo.

Luxury is a state of mind.
Il lusso è un'attitudine.



The entire Maxema collection is available in post-consumer recycled plastic on request /
Tutta la collezione Maxema è realizzabile in plastica riciclata post-consumo su richiesta

Technical information at p. 290
Informazioni tecniche a pag. 290

Chrome finish metal barrel, tip and push-button, solid colour clip with glossy finish

Metal details with diamond mirror finish.

Fusto, punta e tappino in metallo con finitura cromata, clip in colore coprente lucido

Finitura a specchio diamantata per i particolari in metallo.



01 70 03 18 15



74 burgundy / pad printing 40 x 9 mm
74 bordeaux / tampografia 40 x 9 mm



60 61 71 25 72 73

MY BOX

All Mood models come with a single My Box case in black Fedrigoni cardboard included. Info at p. 311

Tutti i modelli Mood vengono forniti con astuccio singolo My Box in cartoncino nero Fedrigoni incluso. Info pag. 311



79 09



75 dark green / pad printing 40 x 9 mm
75 verde scuro / tampografia 40 x 9 mm



26 27 64 77 12 22 05 04

MD1 | M M4

Titanium grey finish metal barrel, tip and push-button, solid colour clip with glossy finish

New titanium grey finish: metal in a dynamic version.

Fusto, punta e tappino in metallo con finitura grigio titanio, clip in colore coprente lucido

Nuova finitura grigio titanio: il metallo in versione dinamica.



70 03 18 15 74 60 71 72



73 79 09 75 27 77 22 05

04 black / pad printing 40 x 9 mm
04 nero / tampografia 40 x 9 mm

01 white / pad printing 40 x 9 mm
01 bianco / tampografia 40 x 9 mm

MY BOX

All Mood models come with a single My Box case in black Fedrigoni cardboard included.
Info at p. 311

*Tutti i modelli Mood vengono forniti con astuccio singolo My Box in cartoncino nero Fedrigoni incluso.
Info pag. 311*



MD1 | M M2

01 white / pad printing 40 x 9 mm
01 bianco / tampografia 40 x 9 mm



Gold finish metal barrel, tip and push-button, solid colour clip with glossy finish

Metal with gold finish: pure light.

MY BOX

All Mood Metal models come with a single My Box case in black Fedrigoni cardboard included. Info at p. 311

Tutti i modelli Mood Metal vengono forniti con astuccio singolo My Box in cartoncino nero Fedrigoni incluso. Info pag. 311

04 black / pad printing 40 x 9 mm
04 nero / tampografia 40 x 9 mm



Fusto, punta e tappino in metallo con finitura dorata, clip in colore coprente lucido

Metallo con finitura oro: luce allo stato puro.

Mood

Design with a metal touch.
Il design incontra il metallo.

Luxury is a state of mind.
Il lusso è un'attitudine.

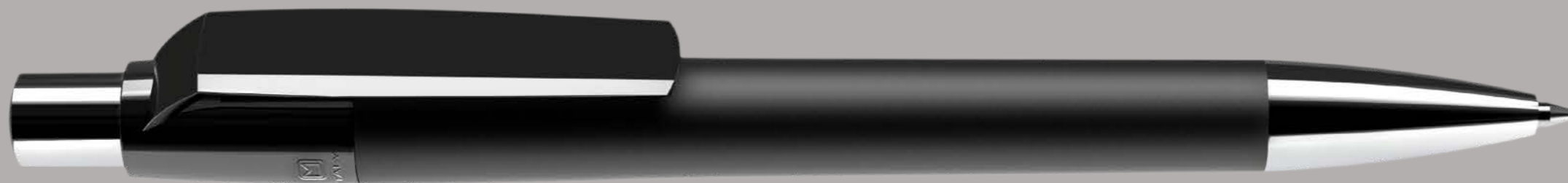

The entire Maxema collection is available in post-consumer recycled plastic on request /
Tutta la collezione Maxema è realizzabile in plastica riciclata post-consumo su richiesta

Technical information at p. 291
Informazioni tecniche a pag. 291

Solid colours with glossy finish,
chrome finish metal tip and push-button

Fast Dry Gel

Blue and black
Fast Dry Gel ink
refills available for
all Mood versions.

Colori coprenti con finitura lucida,
punta e tappino in metallo
con finitura cromata

Fast Dry Gel

Refill gel Fast
Dry blu e nero
disponibili su
richiesta per tutte
le versioni Mood.

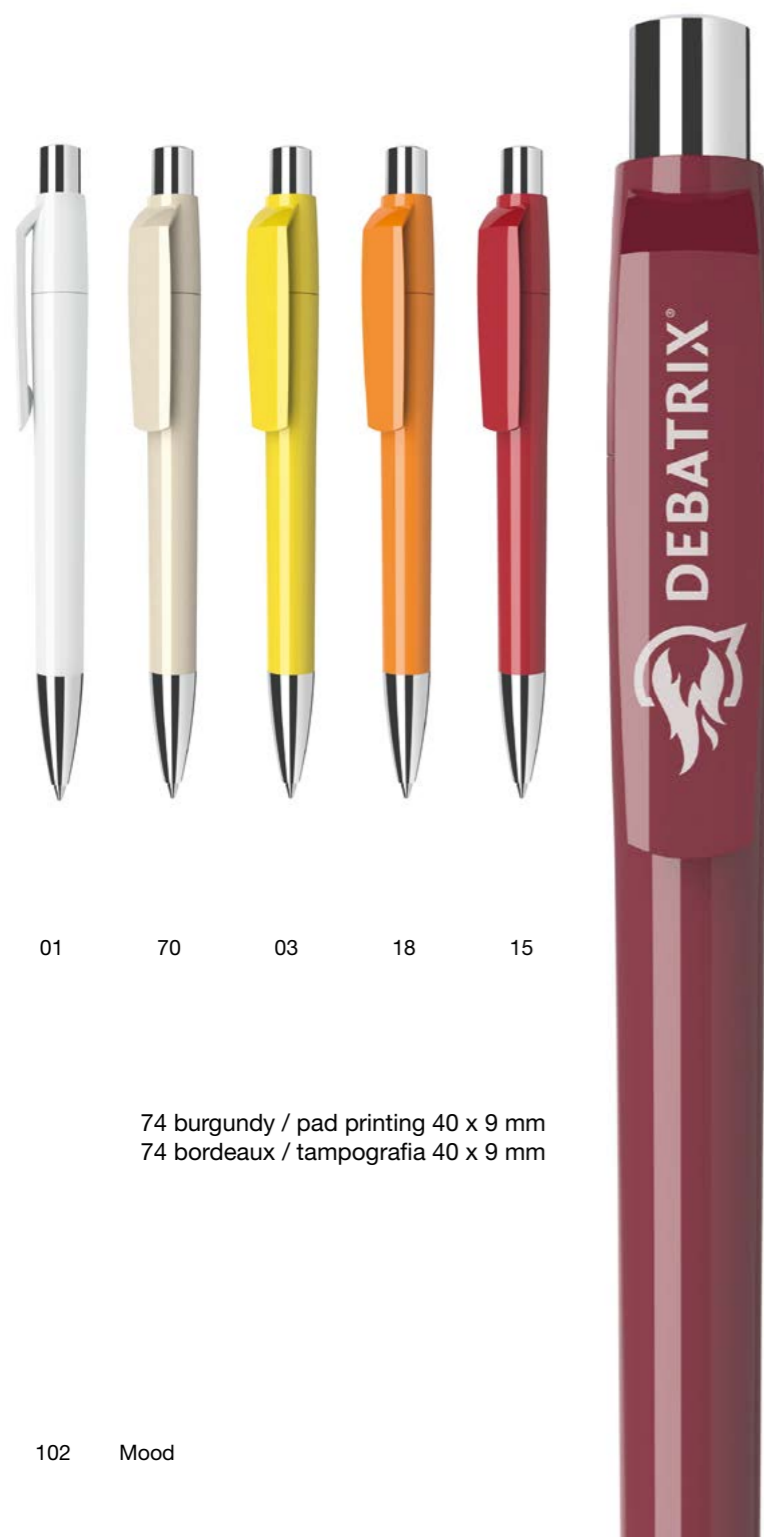

01 70 03 18 15

74 burgundy / pad printing 40 x 9 mm
74 bordeaux / tampografia 40 x 9 mm



60 61 71 25 72

MY BOX

All Mood models come with a single
My Box case in black Fedrigoni
cardboard included.
Info at p. 311

*Tutti i modelli Mood vengono forniti
con astuccio singolo My Box in
cartoncino nero Fedrigoni incluso.
Info pag. 311*



73 79 09 75 26

27 octan green / pad printing 40 x 9 mm
27 ottanio / tampografia 40 x 9 mm



64 77 12 22 05 04

MD1 | GOM CB M1

Solid colour barrel with rubber finish,
solid glossy white colour clip,
chrome finish metal tip and push-button

18 orange / pad printing 40 x 9 mm
18 arancio / tampografia 40 x 9 mm



03

15

74

cy°zone

61

71

25

72

73

60 pink / pad printing 40 x 9 mm
60 rosa / tampografia 40 x 9 mm

BANYAN TREE
GROUP

75 dark green / pad printing 40 x 9 mm
75 verde scuro / tampografia 40 x 9 mm



79

09

26

27

64

77

12

22

05

04

Fusto in colore coprente gommato,
clip in colore bianco lucido, punta
e tappino in metallo con finitura
cromata

MY BOX

All Mood models come with a single
My Box case in black Fedrigoni
cardboard included.
Info at p. 311

*Tutti i modelli Mood vengono forniti
con astuccio singolo My Box in
cartoncino nero Fedrigoni incluso.
Info pag. 311*

Solid colour barrel with rubber finish,
solid colour clip with glossy finish,
chrome finish metal tip and push-button

Result of
superior quality
craftsmanship.

Fusto in colore coprente gommato,
clip in colore coprente con finitura
lucida, punta e tappino in metallo
con finitura cromata

Risultato
di lavorazioni
artigiane di
qualità superiore.



70 03 18 15 74 60 61 71 25 72 73



79 09 75 26 27 64 77 12 22 05



04 black / pad printing 40 x 9 mm
04 nero / tampografia 40 x 9 mm

MY BOX

All Mood models come with a single
My Box case in black Fedrigoni
cardboard included.
Info at p. 311

*Tutti i modelli Mood vengono forniti
con astuccio singolo My Box in
cartoncino nero Fedrigoni incluso.
Info pag. 311*

Solid colour barrel with rubber finish, transparent colour clip with glossy finish, chrome finish metal tip and push-button

Fusto in colore coprente gommato, clip in colore trasparente con finitura lucida, punta e tappino in metallo con finitura cromata

31 light violet / pad printing 40 x 9 mm
31 viola chiaro / tampografia 40 x 9 mm

52 yellow / pad printing 40 x 9 mm
52 giallo / tampografia 40 x 9 mm

78 lime / pad printing 40 x 9 mm
78 lime / tampografia 40 x 9 mm



39

53

45

59

41

55

37

38

49

47

34

67

44

30

50

MY BOX

All Mood models come with a single My Box case in black Fedrigoni cardboard included.
Info at p. 311

*Tutti i modelli Mood vengono forniti con astuccio singolo My Box in cartoncino nero Fedrigoni incluso.
Info pag. 311*

MD1 | C M2



01

04 black / pad printing 40 x 9 mm
04 nero / tampografia 40 x 9 mm

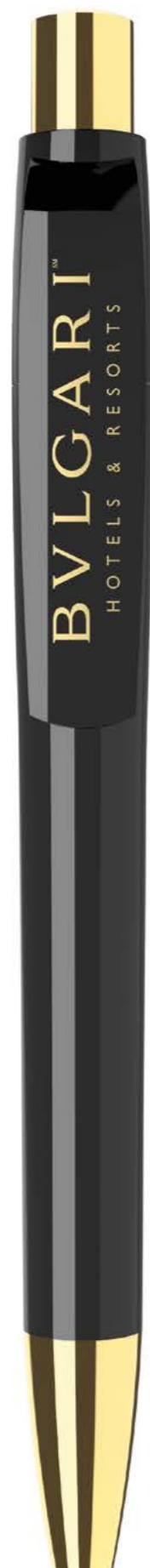

Solid colours with glossy finish, gold finish metal tip and push-button

Colori coprenti con finitura lucida, punta e tappino in metallo con finitura dorata



MD1 | C M3



01

04 black / pad printing 40 x 9 mm
04 nero / tampografia 40 x 9 mm



Solid colours with glossy finish, rose gold metal tip and push button

Colori coprenti con finitura lucida, punta e tappino in metallo con finitura oro rosa

Rose gold, in line with the colour trends of the moment.

Oro rosa, in linea con i trend cromatici del momento.

MY BOX

All Mood Metal models come with a single My Box case in black Fedrigoni cardboard included. Info at p. 311

Tutti i modelli Mood Metal vengono forniti con astuccio singolo My Box in cartoncino nero Fedrigoni incluso. Info pag. 311

Icon Pure

All over soft touch.
Soft touch integrale.

All-round personality.
Personalità a tutto tondo.



The entire Maxema collection is available in post-consumer recycled plastic on request /
Tutta la collezione Maxema è realizzabile in plastica riciclata post-consumo su richiesta

Technical information at p. 292
Informazioni tecniche a pag. 292

Solid colours with rubber finish

Full rubber coating on the entire pen: for printing recommendations, please refer to the technical data sheet on page 260.



15 74 60 61 71 25 72 73

18 orange / pad printing 35 x 7 mm
18 arancio / tampografia 35 x 7 mm

Colori coprenti con finitura gommata

Gommatura integrale su tutta la penna: per i consigli di stampa consultare la scheda tecnica a pag. 260



79 09 26 27 64 77 12 22 05 04

75 dark green / pad printing 35 x 7 mm
75 verde scuro / tampografia 35 x 7 mm

Flow Pure

Free from extra.
Pura ed essenziale.

The essence of design.
L'essenza del design.



The entire Maxema collection is available in post-consumer recycled plastic on request /
Tutta la collezione Maxema è realizzabile in plastica riciclata post-consumo su richiesta

Technical information at p. 293
Informazioni tecniche a pag. 293

Solid colour barrel and cap with rubber finish, solid colour clip with matt finish

Soft touch with matt finish is the new single-colour combination.



18 orange / pad printing 40 x 9 mm
18 arancio / tampografia 40 x 9 mm

Fusto e cappuccio in colore coprente gommato, clip in colore coprente satinato

Soft touch con satinato è il nuovo abbinamento in versione monocromatica.



26 aquamarine / pad printing 40 x 9 mm
26 acquamarina / tampografia 40 x 9 mm

F2P | MATT CB

Solid colour barrel and cap, solid white colour clip, matt finishes

Matt finish and white clip for maximum freedom of personalisation.

Fusto e cappuccio in colore coprente, clip in colore bianco coprente, finiture satinat

Finitura matt e clip bianca per la massima libertà di personalizzazione.



70 03 18 15 74 60 61 71 25 72 73 79



09 75 26 27 64 77 12 22



04

05 grey / pad printing 40 x 9 mm
05 grigio / tampografia 40 x 9 mm

Solid colours with matt finish

All the expressive force of colour in a matt version.

Colori coprenti con finitura satinata

Tutta la forza espressiva del colore in versione satinata.



Solid fluo colours with matt finish

The matt finish
lights up with
fluo colours.

FLUO



02



14

17 orange / pad printing 40 x 9 mm
17 arancio / tampografia 40 x 9 mm

Colori fluo coprenti
con finitura satinata

La finitura satinata
si accende
con i colori fluo.

FLUO



08

56 fuchsia / pad printing 40 x 9 mm
56 fucsia / tampografia 40 x 9 mm

Solid colours with glossy finish

The colours stand out due to the brilliance of the gloss finish.

Colori coprenti con finitura lucida

I colori risaltano grazie alla brillantezza della finitura lucida.



01 70 03 18 15 74



60 pink / pad printing 40 x 9 mm
60 rosa / tampografia 40 x 9 mm



61 71 25 72



73 79 09 75 26 27 64 77 12 22 05 04

F2P | GOM K

Solid black barrel and cap with rubber finish, solid colour clip with glossy finish



70 cream / pad printing 40 x 9 mm
70 crema / tampografia 40 x 9 mm



03



18 orange / pad printing 40 x 9 mm
18 arancio / tampografia 40 x 9 mm



15



60



61



71



72



79



09



Fusto e cappuccio in colore nero coprente gommato, clip in colore coprente lucido



27



64



77



12



05



04

26 aquamarine / pad printing 40 x 9 mm
26 acquamarina / tampografia 40 x 9 mm

F2P | GOM CB

Solid colour barrel and cap with rubber finish, solid white colour clip with glossy finish

Rubberised all over: soft touch barrel and cap.

60 pink / pad printing 40 x 9 mm
60 rosa / tampografia 40 x 9 mm



01 03 18 15 74



61



25 73

71 light violet / pad printing 40 x 9 mm
71 viola chiaro / tampografia 40 x 9 mm

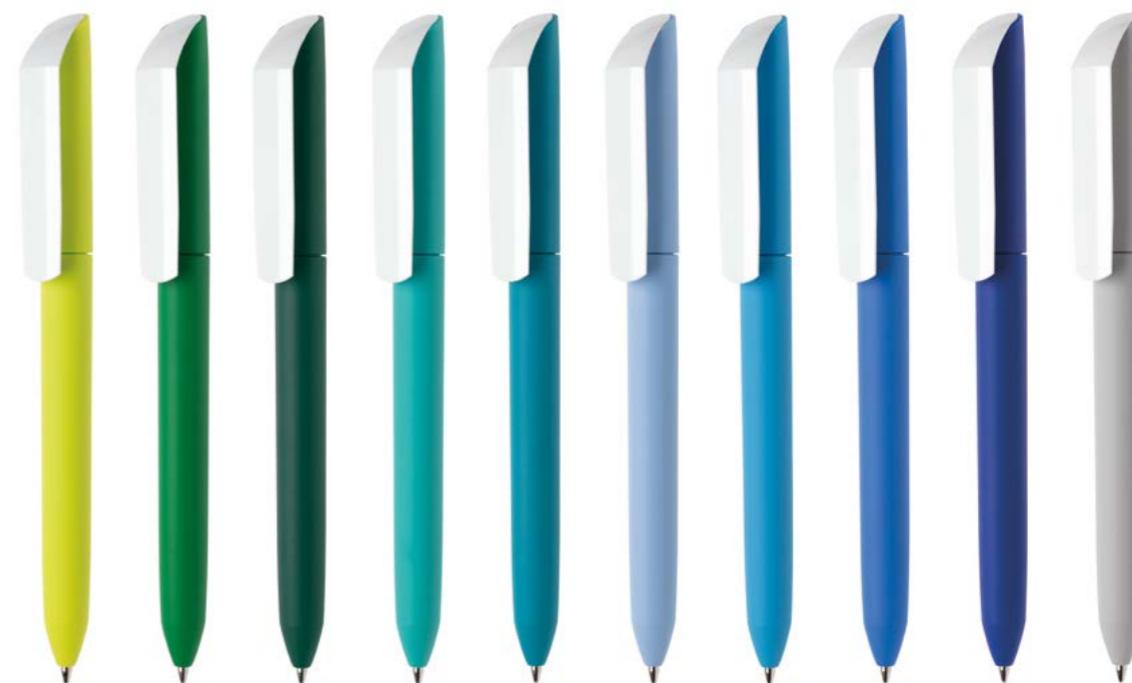

79 09 75 26 27 64 77 12 22 05

04 black / pad printing 40 x 9 mm
04 nero / tampografia 40 x 9 mm

Fusto e cappuccio in colore coprente gommato, clip in colore bianco coprente lucido

Gommatura integrale: fusto e cappuccio soft touch.



Solid colour barrel and cap with rubber finish, transparent colour clip with glossy finish

Even the rubberised barrel can be pad or silk-screen printed.



39 52 53 45 59 41 31 55 37

38 brown / pad printing 40 x 9 mm
38 marrone / tampografia 40 x 9 mm

Fusto e cappuccio in colore coprente gommato, clip in colore trasparente lucido

Anche il fusto è stampabile con tampografia o serigrafia.



49 green / pad printing 50 x 9 mm
49 verde / tampografia 50 x 9 mm

47 34 67 44 30

50 dark grey / pad printing 40 x 9 mm
50 grigio scuro / tampografia 40 x 9 mm

F2P | GOM CF

Solid fluo colour barrel and cap with rubber finish, solid fluo colour clip with glossy finish

Fusto e cappuccio in colore fluo coprente gommato, clip in colore fluo coprente lucido.

FLUO



02

17

14

56 fuchsia / pad printing 40 x 9 mm
56 fucsia / tampografia 40 x 9 mm



08

F2P | GOM KF

Solid black colour barrel and cap with rubber finish, solid fluo colour clip with glossy finish

Fusto e cappuccio in colore nero coprente gommato, clip in colore fluo coprente lucido.

FLUO



02 yellow / pad printing 40 x 9 mm
02 giallo / tampografia 40 x 9 mm



17



56



08

14 coral red / pad printing 40 x 9 mm
14 rosso corallo / tampografia 40 x 9 mm

Solid fluo colour barrel and cap with rubber finish, transparent fluo colour clip with glossy finish.

Minimal profile and compact volumes.

FLUO



MY BOX

Universal reclosable single pen box in Fedrigoni black card. Info at p. 311

Astuccio universale richiudibile per penna singola in cartoncino nero Fedrigoni. Info pag. 311



20



33 orange / pad printing 40 x 9 mm
33 arancio / tampografia 40 x 9 mm



24



46

48 green / pad printing 40 x 9 mm
48 verde / tampografia 40 x 9 mm



Fusto e cappuccio in colore fluo coprente gommato, clip in colore fluo trasparente lucido.

Profilo minimal e volumi compatti.

FLUO

Flow

Feel the change.
Senti il cambiamento.

Evolution of shape,
with and without texturing.

*L'evoluzione della forma,
con e senza texture.*



The entire Maxema collection is available in post-consumer recycled plastic on request /
Tutta la collezione Maxema è realizzabile in plastica riciclata post-consumo su richiesta

Technical information at p. 294
Informazioni tecniche a pag. 294

F1 MATT AL

Solid colours with matt finish,
aluminium painted finish tip

Matt colours
and aluminium
colour tip: satin
style elegance.



01 70 03 18 15 74 60 61 71 25 73

Colori coprenti con finitura
satinata, punta verniciata
in colore alluminio

Colori matt
e punta color
alluminio:
eleganza in
versione satinata.

79 lime / pad printing 40 x 9 mm
79 lime / tampografia 40 x 9 mm



09 75 26 27 64

77 cyan / pad printing 40 x 9 mm
77 ciano / tampografia 40 x 9 mm



12 22 05 04

Solid colours with glossy finish,
chromed tip

Colori coprenti con finitura lucida,
punta cromata



70 03 18 15 74 60 61 71 25 73

01 white / pad printing 40 x 9 mm
01 bianco / tampografia 40 x 9 mm

77 cyan / pad printing 40 x 9 mm
77 ciano / tampografia 40 x 9 mm



79 09 75 26 27 64

77 cyan / pad printing 46 x 9 mm
77 ciano / tampografia 46 x 9 mm



12 22 05 04

F1T | GOM C CR

Solid colour barrel with rubber finish, solid colour clip with glossy finish, textured solid colour cap with matt finish, chromed tip

Distinctive feature: textured cap.

Fusto in colore coprente gommato, clip in colore coprente lucido, cappuccio texturizzato in colore coprente con finitura satinata, punta cromata

Elemento distintivo: cappuccio arricchito da una texture.



01 70 03



15 74 60 61 71 25 73

18 orange / pad printing 40 x 9 mm
18 arancio / tampografia 40 x 9 mm



79 09 75 26 27 64 77 12 22 05

04 black / pad printing 40 x 9 mm
04 nero / tampografia 40 x 9 mm



F1T | GOM CB CR

Solid colour barrel with rubber finish, solid glossy white colour clip, textured solid colour cap with matt finish, chromed tip

Textured with small hexagonal cells that recall a honeycomb: a dynamic design of visual and tactile elegance.

Fusto in colore coprente gommato, clip in colore bianco lucido, cappuccio texturizzato in colore coprente con finitura satinata, punta cromata

Texture costituita da piccole celle esagonali che ricordano un nido d'ape: un design dinamico che dona eleganza visiva e tattile.

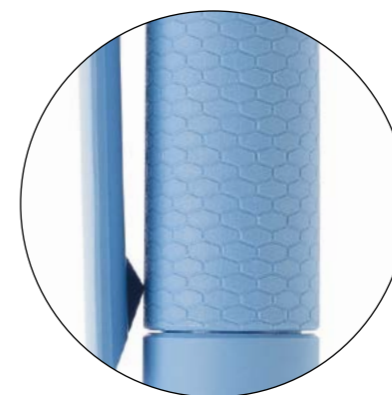

03

18

15

74

60

61

71

25

79

09

75

27

64

77

12

22

04

73 brown / pad printing 40 x 9 mm
73 marrone / tampografia 40 x 9 mm

26 aquamarine / pad printing 40 x 9 mm
26 acquamarina / tampografia 40 x 9 mm

05 grey / pad printing 40 x 9 mm
05 grigio / tampografia 40 x 9 mm

F1T | GOM 30 CR

Solid colour barrel with rubber finish, transparent glossy colour clip, textured solid colour cap with matt finish, chromed tip



59 pink / pad printing 40 x 9 mm
59 rosa / tampografia 40 x 9 mm

Fusto in colore coprente gommato, clip in colore trasparente lucido, cappuccio texturizzato in colore coprente con finitura satinata, punta cromata

30 light grey / pad printing 40 x 9 mm
30 grigio chiaro / tampografia 40 x 9 mm



34 pastel blue / pad printing 40 x 9 mm
34 azzurro pastello / tampografia 40 x 9 mm

Dot

Different from the rest, full stop.
Diversa da tutte, punto.

A pen that reveals
its originality in its details.
*È nei dettagli che rivela
la sua originalità.*



The entire Maxema collection is available in post-consumer recycled plastic on request /
Tutta la collezione Maxema è realizzabile in plastica riciclata post-consumo su richiesta

Technical information at p. 295
Informazioni tecniche a pag. 295

Solid white colour barrel, clip and push-button with matt finish, solid glossy colour little sphere

The matt finish enhances the design and offers new tactile sensations.



01
03 yellow / pad printing 40 x 9 mm
03 giallo / tampografia 40 x 9 mm

The touch of colour stands out against the pure white.

Fusto, clip e tappino in colore bianco coprente con finitura satinata, piccola sfera in colore coprente lucido

La finitura satinata esalta il design e offre nuove sensazioni tattili.



Il punto di colore spicca nella nitidezza del bianco.

D1 MATT CB

Solid colour barrel with matt finish,
solid matt white clip and push-
button, solid glossy colour
little sphere



03 18 15 74

60 pink / pad printing 40 x 9 mm
60 rosa / tampografia 40 x 9 mm

Fusto in colore coprente con finitura
satinata, clip e tappino in colore
bianco coprente satinato, piccola
sfera in colore coprente lucido



79 09 75 26 27 64 77

12 light blue / pad printing 40 x 9 mm
12 azzurro / tampografia 40 x 9 mm

22 05 04

D1 MATT

Solid colours with matt finish, solid glossy colour little sphere

Attractive and refined: the integral matt finish.



70 03 18 15 74 60 61

71 light violet / pad printing 40 x 9 mm
71 viola chiaro / tampografia 40 x 9 mm



25 72 73

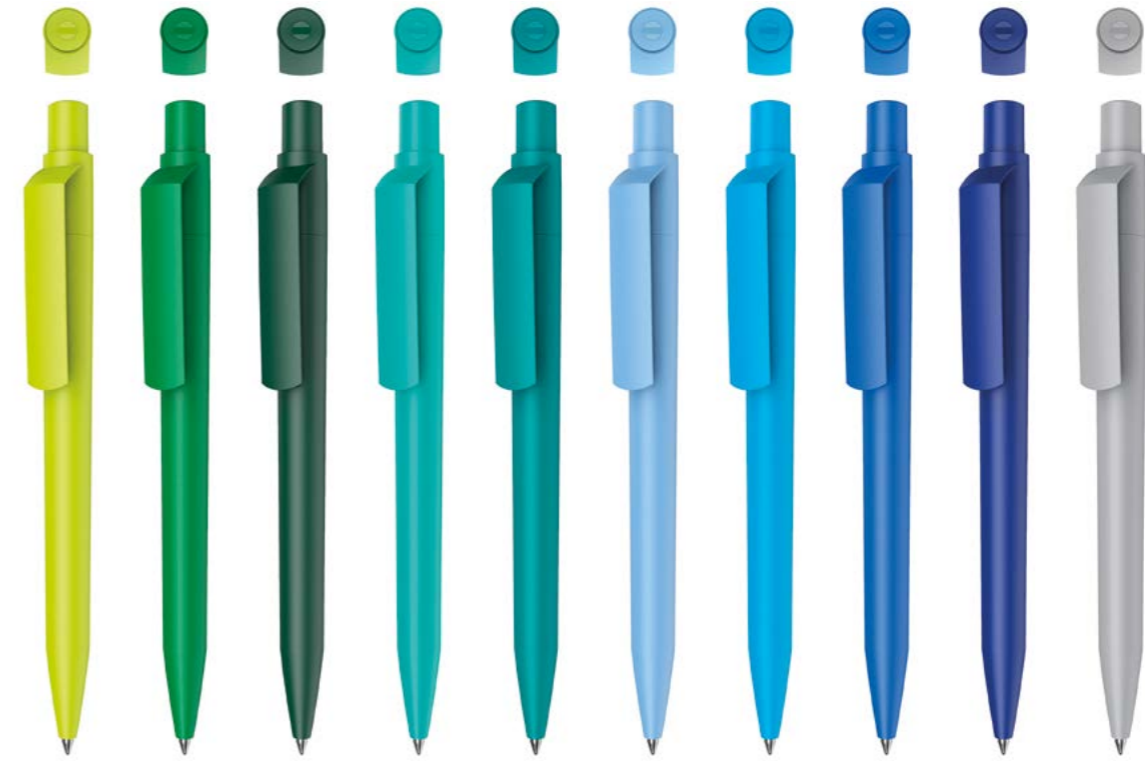

79 09 75 26 27 64 77 12 22 05

04 black / pad printing 40 x 9 mm
04 nero / tampografia 40 x 9 mm

Colori coprenti con finitura satinata, piccola sfera in colore coprente lucido

Attraente e raffinata: è la finitura satinata integrale.



Solid black colour barrel, clip and push-button with matt finish, solid glossy colour little sphere

Purity of lines and matt finish: simply elegant.



70 cream / pad printing 40 x 9 mm
70 crema / tampografia 40 x 9 mm

Minimal black is combined with a discreet touch of colour.

Fusto, clip e tappino in colore nero coprente con finitura satinata, piccola sfera in colore coprente lucido

Purezza di linee e finitura matt: semplicemente elegante.

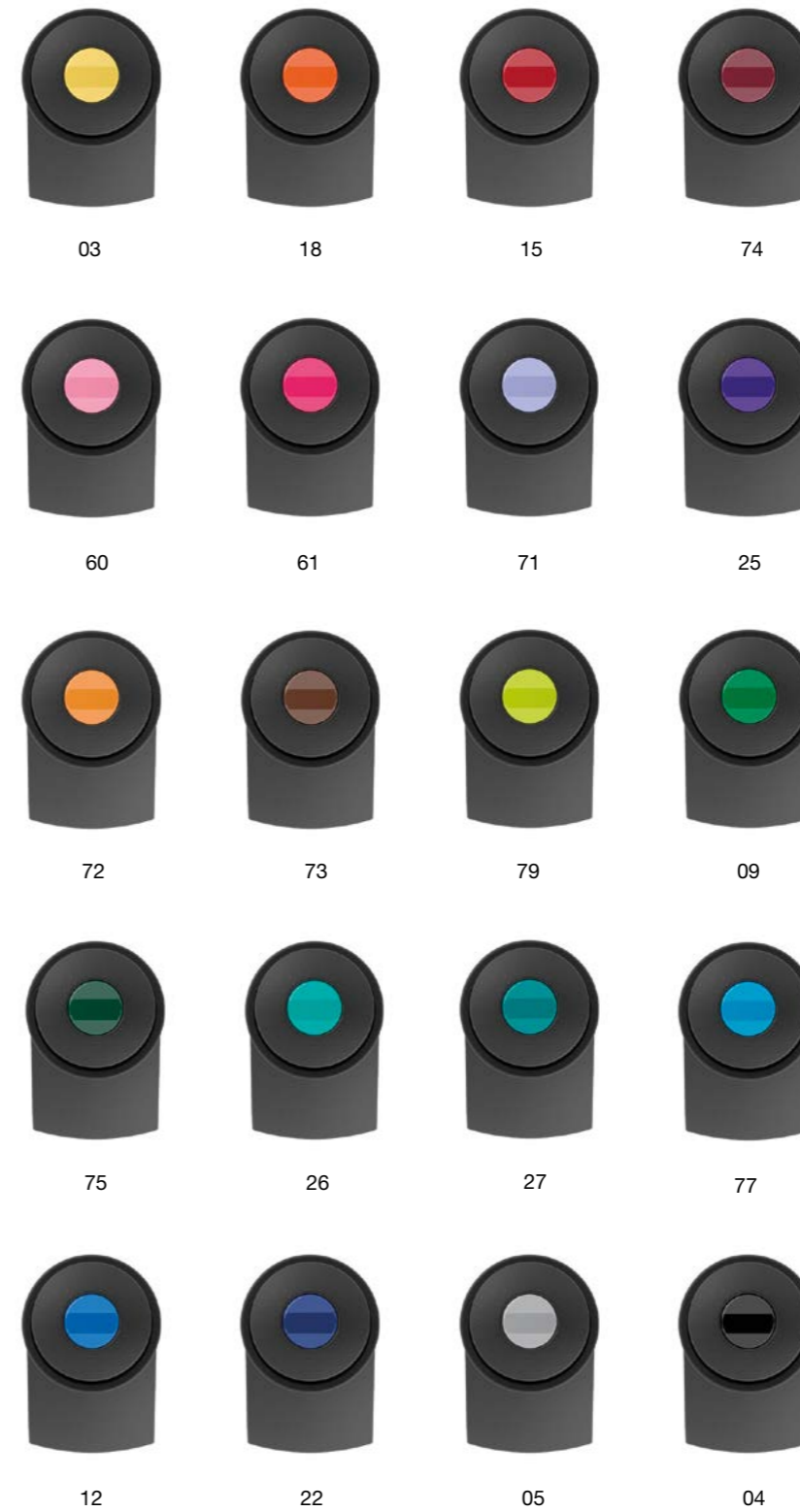

Il nero minimal è abbinato a una piccola e discreta nota di colore.

Solid fluo colours with matt finish,
solid glossy fluo colour little sphere

A more profound
chromatic impact
thanks to the fluo
colours.



02



17

Colori fluo coprenti con finitura
satinata, piccola sfera in colore fluo
coprente lucido

Impatto cromatico
più incisivo
grazie ai colori
fluo.



56



08

14 coral red / pad printing 40 x 9 mm
14 rosso corallo / tampografia 40 x 9 mm

Solid white colour barrel and clip with glossy finish, solid glossy colour little sphere, chromed push-button

A white surface is the creative foundation par excellence: freedom of expression and top colour rendering.

Total white: basic and elegant thanks to its refined colour detail.



01

03 yellow / pad printing 40 x 9 mm
03 giallo / tampografia 40 x 9 mm

Fusto e clip in colore bianco coprente con finitura lucida, piccola sfera in colore coprente lucido, tappino cromato

La superficie bianca è la base creativa per eccellenza: libertà di espressione e massima resa cromatica.

Total white: essenziale ed elegante grazie al raffinato dettaglio di colore.



D1 CB CR

Solid colour barrel and little sphere with glossy finish, solid glossy white colour clip, chromed push-button

Fusto e piccola sfera coprente lucido, clip in colore bianco coprente lucido, tappino cromato



03

18

74

60

61

71

25

73

79

09

75

27

64

77

12

22

05

15 red / pad printing 40 x 9 mm
15 rosso / tampografia 40 x 9 mm

04 black /
pad printing
40 x 9 mm
04 nero /
tampografia
40 x 9 mm

D1 | C CR

Solid colours with glossy finish,
chromed push-button

Colori coprenti con finitura lucida,
tappino cromato

74 burgundy / pad printing 40 x 9 mm
74 bordeaux / tampografia 40 x 9 mm

64 pastel blue / pad printing 40 x 9 mm
64 azzurro pastello / tampografia 40 x 9 mm



70

03

15

60

61

71

25

73

79

09

75

27

77

12

22

05

18 orange /
pad printing
40 x 9 mm
18 arancio /
tampografia
40 x 9 mm

04 black /
pad printing
40 x 9 mm
04 nero /
tampografia
40 x 9 mm

D1 30 CR

Transparent colours with glossy finish, solid glossy colour little sphere, chromed push-button

Colori trasparenti con finitura lucida, piccola sfera in colore coprente lucido, tappino cromato



39

53

45

41

55

37

38

52 yellow / pad printing 40 x 9 mm
52 giallo / tampografia 40 x 9 mm

49

47

67

44

50

78 lime /
pad printing
40 x 9 mm
78 lime /
tampografia
40 x 9 mm

Solid black colour barrel with rubber finish, solid black colour clip and push-button with glossy finish, solid glossy colour little sphere

The elegance of black combines with a soft touch finish for a high-impact result.



01

70 cream / pad printing 40 x 9 mm
70 crema / tampografia 40 x 9 mm



Total black with a note of colour.



03



18



15



74



60



61



71



25



72



73



79



09



75



26



27



77



12



22



05



04

Fusto in colore nero coprente gommato, clip e tappino in colore nero coprente lucido, piccola sfera in colore coprente lucido

L'eleganza del nero si combina con la finitura soft touch per un risultato di grande impatto.

Total black con nota di colore.

Solid colour barrel with rubber finish, solid glossy white colour clip, solid glossy colour little sphere, chromed push-button



01 03

15 74 60 61 71

73

18 orange /
pad printing
40 x 9 mm
18 arancio /
tampografia
40 x 9 mm

25 dark violet /
pad printing
40 x 9 mm
25 viola scuro /
tampografia
40 x 9 mm

64 pastel blue / pad printing 40 x 9 mm
64 azzurro pastello / tampografia 40 x 9 mm



79 09 75 26 27

77 12 22

04

05 grey /
pad printing
40 x 9 mm
05 grigio /
tampografia
40 x 9 mm

Fusto in colore coprente gommato, clip in colore bianco coprente lucido, piccola sfera in colore coprente lucido, tappino cromato

D1 | GOM C CR

Solid colour barrel with rubber finish, solid colour clip and little sphere with glossy finish, chromed push-button

Fusto in colore coprente gommato, clip e piccola sfera in colore coprente con finitura lucida, tappino cromato



71 light violet / pad printing 40 x 9 mm
71 viola chiaro / tampografia 40 x 9 mm

22 blue / pad printing 40 x 9 mm
22 blu / tampografia 40 x 9 mm

03 yellow / pad printing 40 x 9 mm
03 giallo / tampografia 40 x 9 mm

D1 | GOM 30 CR

Solid colour barrel with rubber finish, transparent colour clip with glossy finish, solid glossy colour little sphere, chromed push-button



39 52 53 45 59 41 31 55 37

38 brown / pad printing 40 x 9 mm
38 marrone / tampografia 40 x 9 mm

Fusto in colore coprente gommato, clip in colore trasparente con finitura lucida, piccola sfera in colore coprente lucido, tappino cromato



78 49 47 34 67 44 30

50 dark grey / pad printing 40 x 9 mm
50 grigio scuro / tampografia 40 x 9 mm

D1 | C GOLD

Solid colours with glossy finish,
gilded push-button

*Colori coprenti con finitura lucida,
tappino dorato*



01 white / pad printing 40 x 9 mm
01 bianco / tampografia 40 x 9 mm



04

D1 | GOM KF CR

Solid black colour barrel with rubber
finish, solid fluo colour clip
and little sphere with glossy finish,
chromed push-button

*Fusto in colore nero coprente
gommato, clip e piccola sfera
in colore fluo coprente lucido,
tappino cromato*



02

17 orange /
pad printing
40 x 9 mm
17 arancio /
tampografia
40 x 9 mm



56



08

14 coral red / pad printing 40 x 9 mm
14 rosso corallo / tampografia 40 x 9 mm

Zink

Solid geometries.
Solide geometrie.

A pen with a
clean-cut profile
and strong personality.

*Una penna
dal profilo tagliente
e dal carattere deciso.*



The entire Maxema collection is available in post-consumer recycled plastic on request /
Tutta la collezione Maxema è realizzabile in plastica riciclata post-consumo su richiesta

Technical information at p. 296
Informazioni tecniche a pag. 296

Solid colours barrel, solid white colour cap, glossy finishes

More suitability for multi-colour printing with white clip.

Fusto in colori coprenti, cappuccio in colore bianco coprente, finiture lucide

Maggiore versatilità per la stampa a più colori con la clip bianca.



70 03 18 15 74



61 71 25 73

60 pink / pad printing 43 x 9 mm
60 rosa / tampografia 43 x 9 mm

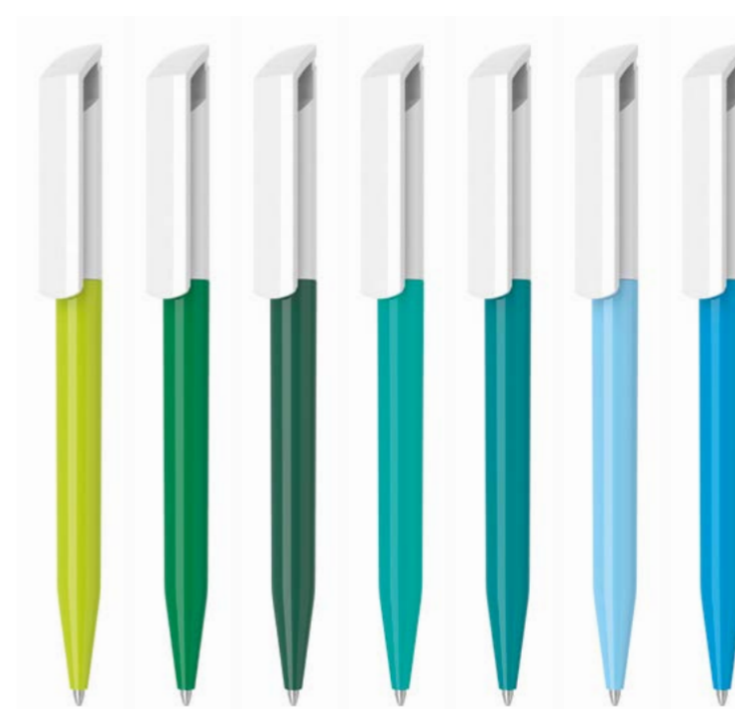

79 09 75 26 27 64 77

12 light blue / pad printing 43 x 9 mm
12 azzurro / tampografia 43 x 9 mm



22 05 04

Solid colours with glossy finish

Solid, sturdy architecture for a profile of geometric precision.

Colori coprenti con finitura lucida

Architettura corposa e robusta per un profilo dal rigore geometrico.



01 70 03



18 orange / pad printing 43 x 9 mm
18 arancio / tampografia 43 x 9 mm



15 74 60 61 25 73



79 09 75



64 77 12 22

05 grey / pad printing 43 x 9 mm
05 grigio / tampografia 43 x 9 mm



27 octan green / pad printing 43 x 9 mm
27 ottanio / tampografia 43 x 9 mm



04

Transparent colours with glossy finish

Its sturdy structure is offset by the slim, streamlined barrel.



39 52 53 45 59 41 51 31 55

37 amber / pad printing 43 x 9 mm
37 ambra / tampografia 43 x 9 mm



Colori trasparenti con finitura lucida

Il fusto slanciato bilancia la solida struttura.

67 cyan / pad printing 43 x 9 mm
67 ciano / tampografia 43 x 9 mm



38 78 49 47



44 30 50

Solid fluo colours with glossy finish

Fluo colours,
intense and
vibrant shades.

FLUO



02



17 orange / pad printing 43 x 9 mm
17 arancio / tampografia 43 x 9 mm



14

56

Colori fluo coprenti
con finitura lucida

Colori fluo,
tonalità intense
e vibranti.

FLUO



08 green / pad printing 43 x 9 mm
08 verde / tampografia 43 x 9 mm

View

Decisive personality.
Carattere incisivo.

Exudes boldness from every angle and captivates with its elegance.

Sprigiona grinta da ogni punto di vista e affascina per l'eleganza.



The entire Maxema collection is available in post-consumer recycled plastic on request /
Tutta la collezione Maxema è realizzabile in plastica riciclata post-consumo su richiesta

Technical information at p. 297
Informazioni tecniche a pag. 297

V1 C CR / C CRT

V1 - C CR clip per incisione laser / clip for laser engraving

V1 - C CRT clip per tampografia / clip for pad printing

Solid colours with glossy finish, metal chrome finish clip, chromed tip

Colori coprenti con finitura lucida, clip in metallo cromato, punta cromata



01 70 03 18 15 74

60 pink / laser engraving 30 x 7 mm
60 rosa / incisione laser 30 x 7 mm



61 71



25 73



79 lime / screen printing 42 x 30 mm
79 lime / serigrafia 42 x 30 mm



09 75 27 64 12

22 blue / pad printing on the clip 40 x 6 mm
22 blu / tampografia su clip 40 x 6 mm



04

V1 | 30 CR / 30 CR T

V1 - 30 CR clip per incisione laser / clip for laser engraving

V1 - 30 CR T clip per tampografia / clip for pad printing

Transparent colours with glossy finish, metal chrome finish clip, chromed tip

Colori trasparenti con finitura lucida, clip in metallo cromato, punta cromata



52 53 45 51 55 49 47 44 40

39 neutral / screen printing 42 x 30 mm
39 neutro / serigrafia 42 x 30 mm

V1 | AL CR / AL CR T

V1 - AL CR clip per incisione laser / clip for laser engraving

V1 - AL CR T clip per tampografia / clip for pad printing

Aluminium painted finish barrel and cap, metal chromed clip, chromed tip

Fusto e cappuccio verniciati in colore alluminio, clip in metallo cromato, punta cromata



The sleek design of the cap adds elegance and balances the large clip.

La linea affilata del cappuccio dà armonia e bilancia l'imponenza della clip.

aluminium / laser engraving 30 x 7 mm
alluminio / incisione laser 30 x 7 mm

V1 GOM C CR / GOM C CR T

V1 - GOM C CR
clip per incisione laser /
clip for laser engraving

V1 - GOM C CR T
clip per tampografia /
clip for pad printing

Solid colour barrel and cap with
rubber finish, metal chrome clip,
chromed tip

Free rein to
colours on
metals too.

Fusto e cappuccio in colore coprente
gommato, clip in metallo cromato,
punta cromata

Via libera ai colori,
anche su metallo.



03

15

74

60

18 orange /
pad printing on the clip 40 x 6 mm
18 arancio /
tampografia su clip 40 x 6 mm

CLARINS

71

25

72

61 magenta /
screen printing 42 x 30 mm
61 magenta /
serigrafia 42 x 30 mm

73

79

09

75

27

64 pastel blue / laser engraving 30 x 7 mm
64 azzurro pastello / incisione laser 30 x 7 mm



12

22

04 black / pad printing
on the clip 40 x 6 mm
04 nero / tampografia
su clip 40 x 6 mm



Tag

Imposing elegance.
Eleganza imponente.

Clean-cut, refined
design, a tribute
to perfect elegance.

*Design semplice
e raffinato, omaggio
all'eleganza perfetta.*



The entire Maxema collection is available in post-consumer recycled plastic on request /
Tutta la collezione Maxema è realizzabile in plastica riciclata post-consumo su richiesta

Technical information at p. 298
Informazioni tecniche a pag. 298

TA1 | MATT AL B

Solid white colour barrel and clip with matt finish, solid colour upper plug with glossy finish, aluminium painted finish tip

Fusto e clip in colore bianco coprente con finitura satinata, tassello superiore in colori coprenti con finitura lucida, punta verniciata in colore alluminio

01 white / pad printing 40 x 9 mm
 01 bianco / tampografia 40 x 9 mm
 —
 screen printing 42 x 30 mm
 serigrafia 42 x 30 mm



03 18 15 74

61 magenta / pad printing 40 x 9 mm
 61 magenta / tampografia 40 x 9 mm



71 25



72 73 79 09 27

64 pastel blue / pad printing 40 x 9 mm
 64 azzurro pastello / tampografia 40 x 9 mm



12 22 04

Solid white colour barrel and clip,
solid colour upper plug, glossy
finishes, chromed tip

Elegance and
linearity to express
all the strength
of a brand.

15 red / pad printing 40 x 9 mm
15 rosso / tampografia 40 x 9 mm



03

18

74

61

09

27

12

22



*Fusto e clip in colore bianco, tassello
superiore in colori coprenti, finiture
lucide, punta cromata*

Eleganza e
linearità per
esprimere tutta la
forza di un brand.

04 black / pad printing 40 x 9 mm
04 nero / tampografia 40 x 9 mm

TA1 | C CR

Solid colours with glossy finish,
chromed upper plug and tip

Colori coprenti con finitura lucida,
tassello superiore e punta cromati



01 white / pad printing 40 x 9 mm
01 bianco / tampografia 40 x 9 mm



70 03 18 15 74 60 61 71 25 72



64 pastel blue / pad printing 40 x 9 mm
64 azzurro pastello / tampografia 40 x 9 mm



79 09 75 27

73 brown / pad printing 40 x 9 mm
73 marrone / tampografia 40 x 9 mm



12 22 04

TA1 | MET AL

Metallic colours painted finish barrel and clip, aluminium painted finish upper plug and tip

Fusto e clip verniciati in colori metallizzati, tassello superiore e punta verniciati in colore alluminio



92

83



94

95

96



MY BOX

Universal reclosable single pen box in Fedrigoni black card. Info at p. 311

Astuccio universale richiudibile per penna singola in cartoncino nero Fedrigoni. Info pag. 311

85 red / pad printing 40 x 9 mm
85 rosso / tampografia 40 x 9 mm

TA1 | AL CR

Aluminium painted finish barrel and clip, chromium upper plug and tip

Fusto e clip verniciati in colore alluminio, tassello superiore e punta cromati

Its rigorous styling is softened by the smooth curve of the clip and closing plug.

Lo stile rigoroso è ingentilito dalla dolce curvatura della clip e del suo tassello di chiusura.



aluminium / pad printing 40 x 9 mm
alluminio / tampografia 40 x 9 mm

Icon

Timeless design.
Design senza tempo.

A perfect synthesis of
past, present and future.

*L'incontro tra passato,
presente e futuro.*



The entire Maxema collection is available in post-consumer recycled plastic on request /
Tutta la collezione Maxema è realizzabile in plastica riciclata post-consumo su richiesta

Technical information at p. 299
Informazioni tecniche a pag. 299

IC400 | MATT

Solid colours with matt finish

Colori coprenti con finitura satinata

Essential,
harmonious
design for a style
that is never banal
and always
up-to-date.



01 70 03 18 15 60

79 lime / pad printing 35 x 7 mm
79 lime / tampografia 35 x 7 mm



64 22 04

IC400 | FROST

Transparent colours with matt finish

Colori trasparenti con finitura satinata

Design dal profilo
essenziale e
armonico per uno
stile mai scontato
e sempre attuale.



39 52 53 45

51 violet / screen printing 40 x 30 mm
51 viola / serigrafia 40 x 30 mm



55 49 47

44 blue /
pad printing
35 x 7 mm
44 blu /
tampografia
35 x 7 mm



40

IC400 | MATT AL

Solid colours with matt finish,
aluminium painted finish tip

Colori coprenti con finitura satinata,
punta verniciata in colore alluminio



01 70 03

18 orange /
pad printing 35 x 7 mm
18 arancio /
tampografia 35 x 7 mm



15 74 60 61

71 light violet /
pad printing 35 x 7 mm
71 viola chiaro /
tampografia 35 x 7 mm



25



72 73 79 09 75

27 octan green / pad printing 35 x 7 mm
27 ottanio / tampografia 35 x 7 mm



64 12 22

04 black /
screen printing 40 x 30 mm
04 nero /
serigrafia 40 x 30 mm



Solid colours with glossy finish,
chromed tip

Colori coprenti con finitura lucida,
punta cromata



01 white / pad printing 45 x 9 mm
01 bianco / tampografia 45 x 9 mm



70 03 18 15 74 60

61 magenta / pad printing 35 x 7 mm
61 magenta / tampografia 35 x 7 mm



71 25



72



73 brown / pad printing 35 x 7 mm
73 marrone / tampografia 35 x 7 mm



79 09



27 64 12 22 04

75 dark green / pad printing 35 x 7 mm
75 verde scuro / tampografia 35 x 7 mm

IC400 | FROST AL

Transparent colours, matt finish,
aluminium painted finish tip

*Colori trasparenti con finitura
satinata, punta verniciata in colore
alluminio*

53 orange / pad printing 35 x 7 mm
53 arancio / tampografia 35 x 7 mm
—
screen printing 40 x 30 mm
serigrafia 40 x 30 mm



39

52

45

51

55

49

47

44

40 grey / pad printing 35 x 7 mm
40 grigio / tampografia 35 x 7 mm

IC400 | 30 CR

Transparent colours with
glossy finish, chromed tip

*Colori trasparenti con finitura
lucida, punta cromata*



39

52

53

51

55

49

44

40

45 red /
pad printing 35 x 7 mm
45 rosso /
tampografia 35 x 7 mm

47 aquamarine /
pad printing 35 x 7 mm
47 acquamarina /
tampografia 35 x 7 mm

IC400 | C GOLD

04 black / screen printing 40 x 30 mm
04 nero / serigrafia 40 x 30 mm



01 74 75 22



Solid colours with glossy finish, gilded tip

Colori coprenti con finitura lucida, punta dorata



MY CASE

Universal single pen box in Fedrigoni black card.
Info at p. 308

Astuccio universale per penna singola in cartoncino nero Fedrigoni.
Info pag. 308

IC400 | MET AL

Metallic colours painted finish barrel and cap, aluminium painted finish tip

Fusto e cappuccio verniciati in colori metallizzati, punta verniciata in colore alluminio

Exclusive high strength metallic colours.



92

83 copper / pad printing 35 x 7 mm
83 rame / tampografia 35 x 7 mm



85 94 95 96

Esclusivi colori metallizzati ad alta resistenza.

IC400 | AL CR

Aluminium painted finish barrel and cap, chromed tip

Fusto e cappuccio verniciati in colore alluminio, punta cromata



aluminium / pad printing 35 x 7 mm
alluminio / tampografia 35 x 7 mm

Ethic

Elegance and flexibility.
Eleganza e flessibilità.

Tailored to the
customer's
requirements.

*Costruita a misura
di cliente.*



The entire Maxema collection is available in post-consumer recycled plastic on request /
Tutta la collezione Maxema è realizzabile in plastica riciclata post-consumo su richiesta

Technical information at p. 302
Informazioni tecniche a pag. 302

ET900 | MULTICOLOUR

Solid colours with glossy finish, metal chrome finish clip, chromed tip

Colori coprenti con finitura lucida, clip in metallo cromato, punta cromata

Designed to outlast passing fashions, like the message it conveys.

Pensata per durare oltre le mode del momento, come il messaggio che deve trasmettere.



18

09

12

R

B

G green / pad printing 55 x 9,5 mm
G verde / tampografia 55 x 9,5 mm

ET900 | FLAG

Solid colours with glossy finish, metal chrome finish clip, chromed tip

Colori coprenti con finitura lucida, clip in metallo cromato, punta cromata



22

15

04

FR

SP

GE

09

IT / pad printing 55 x 9,5 mm
IT / tampografia 55 x 9,5 mm

ET900 | C FLAG

Solid colours with glossy finish, metal chrome finish clip, chromed tip

Colori coprenti con finitura lucida, clip in metallo cromato, punta cromata



01

01

22 IT

04 IT / pad printing 55 x 9,5 mm
04 IT / tampografia 55 x 9,5 mm

ET900 | B

Solid colours with glossy finish, metal chrome finish clip, chromed tip

Colori coprenti con finitura lucida, clip in metallo cromato, punta cromata



03

18

18 orange /
pad printing
55 x 9,5 mm
18 arancio /
tampografia
55 x 9,5 mm

15

74

25

09

12

22

04 black /
pad printing
55 x 9,5 mm
04 nero /
tampografia
55 x 9,5 mm

04

COENERGIA
group

ET900 | BC

Solid colours with glossy finish, metal chrome finish clip, white top, chromed tip and two rings

Colori coprenti con finitura lucida, clip in metallo cromato, due anelli e punta cromati, tappino bianco



01

70

03

18

15 red / pad printing 30 x 8 mm
15 rosso / tampografia 30 x 8 mm
—
screen printing 45 x 30 mm
serigrafia 45 x 30 mm

aton.eu

74

09

27

12

22

04

ET900 | C CR

Solid colours with glossy finish, metal chrome finish clip, chromed tip, top and two rings

Colori coprenti con finitura lucida, clip in metallo cromato, due anelli, punta e tappino cromati

chrome



01

70

18

15

25

09

75

27

03 yellow /
pad printing
55 x 9,5 mm
03 giallo /
tampografia
55 x 9,5 mm

74 burgundy /
pad printing
55 x 9,5 mm
74 bordeaux /
tampografia
55 x 9,5 mm

ET900 | C GOLD

Solid colours with glossy finish, gilded metal finish clip, gilded tip, top and two rings

Colori coprenti con finitura lucida, clip in metallo dorato, due anelli, punta e tappino dorati

The chrome or gilded details enhance the pen's elegance.

chrome



12

22

04

01 white /
screen printing
45 x 30 mm
01 bianco /
serigrafia
45 x 30 mm

gold



74

27

22

04

I dettagli, cromati o dorati, ne esaltano l'eleganza.

ET900 | AL

Aluminium painted finish barrel, cap and central ring, solid colour two rings and top with glossy finish, metal chrome finish clip, chromed tip

Fusto, cappuccio e anello centrale verniciati in colore alluminio, due anelli e tappino in colore coprente con finitura lucida, clip in metallo cromato, punta cromata



03 18 15 74

09 green / pad printing 55 x 9,5 mm
09 verde / tampografia 55 x 9,5 mm



12 22 04

Refined,
flexible design
for the most
demanding
brands.

ET900 | AL CR

Aluminium painted finish barrel, cap and central ring, metal chrome finish clip, chromed tip, top, and two rings

Fusto, cappuccio e anello centrale verniciati in colore alluminio, clip in metallo cromato, due anelli, tappino e punta cromati



chrome

Design raffinato
e flessibile,
per i brand
più esigenti.

ET900 | AL FLAG

Aluminium painted finish barrel and cap, solid colour rings with glossy finish, metal chrome finish clip, chromed tip

Fusto e cappuccio verniciati in colore alluminio, anelli e tappino in colori coprenti con finitura lucida, clip in metallo cromato, punta cromata



09

IT

ET900 | MET CR

Metallic colours painted finish barrel, cap and central ring, metal chrome finish clip, chromed tip, top and two rings

Fusto, cappuccio e anello centrale verniciati in colori metallizzati, clip in metallo cromato, due anelli, tappino e punta cromati

chrome



91 92 83

85 red /
pad printing
55 x 9,5 mm
85 rosso /
tampografia
55 x 9,5 mm



81 82 89 94

95 blue / pad printing 55 x 9,5 mm
95 blu / tampografia 55 x 9,5 mm



96

ET900 | MET AL

Metallic colours painted finish barrel, cap and central ring, metal aluminium painted finish clip, aluminium painted finish tip, top and two rings

Fusto, cappuccio e anello centrale verniciati in colori metallizzati, clip in metallo verniciato in colore alluminio, due anelli, tappino e punta verniciati in colore alluminio

al



92 83 85 89 94 95

91 pearl / pad printing 30 x 8 mm
91 perla / tampografia 30 x 8 mm



96 anthracite / pad printing 30 x 8 mm
96 antracite / tampografia 30 x 8 mm

Next

The shape for the future
La forma che verrà

Sleek, dynamic lines,
able to boost the
visibility and identity
of every brand.

*Scattante e dinamica:
l'accelerazione positiva
per ogni brand.*



The entire Maxema collection is available in post-consumer recycled plastic on request /
Tutta la collezione Maxema è realizzabile in plastica riciclata post-consumo su richiesta

Technical information at p. 303
Informazioni tecniche a pag. 303

NX400 | C CR

Solid colours with glossy finish,
chromed tip

*Colori coprenti con finitura lucida,
punta cromata*

01 white / pad printing 50 x 10 mm
01 bianco / tampografia 50 x 10 mm



70 03 18 15 74 09 12 22

04 black / pad printing 50 x 10 mm
04 nero / tampografia 50 x 10 mm



NX400 | 30 CR

Transparent colours with glossy finish,
chromed tip

*Colori trasparenti con finitura lucida,
punta cromata*



39 52 53 45

51 violet /
pad printing
35 x 9 mm
51 viola /
tampografia
35 x 9 mm



55 49



44 40

47 aquamarine /
pad printing
35 x 9 mm
47 acquamarina /
tampografia
35 x 9 mm

Pixel

High resolution design.
Il design ad alta definizione.

A synthesis of
contemporary style.

*Sintesi dello stile
contemporaneo.*



The entire Maxema collection is available in post-consumer recycled plastic on request /
Tutta la collezione Maxema è realizzabile in plastica riciclata post-consumo su richiesta

Technical information at p. 304
Informazioni tecniche a pag. 304

PX40 | MATT CB

Solid colour barrel with matt finish, solid glossy white colour clip and push-button

Colours with matt finish and white clip: an easy, gritty combination.



01 70 03 18 15 74 60

61 magenta / pad printing 30 x 8 mm
61 magenta / tampografia 30 x 8 mm



71 25 73

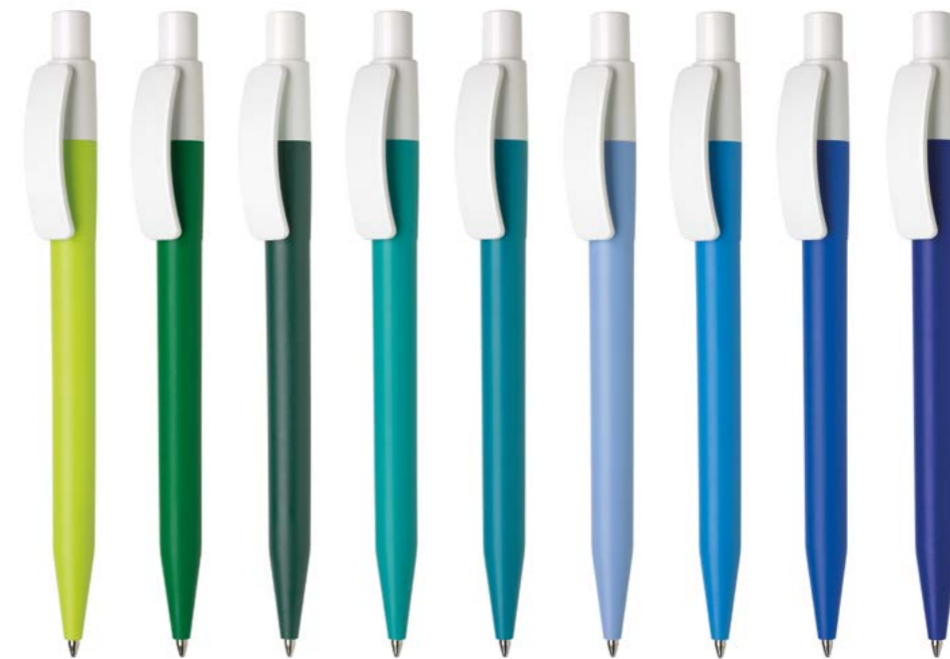

79 09 75 26 27 64 77 12 22

05 grey / pad printing 30 x 8 mm
05 grigio / tampografia 30 x 8 mm

Fusto in colore coprente con finitura satinata, clip e tappino in colore bianco coprente lucido

Colori con finitura matt e clip bianca: una combinazione facile e grintosa.



04

PX40 | MATT CR

Solid colour barrel with matt finish,
solid glossy colour clip, chromed
push-button

Fusto in colore coprente con finitura
satinata, clip in colore coprente
lucido, tappino cromato

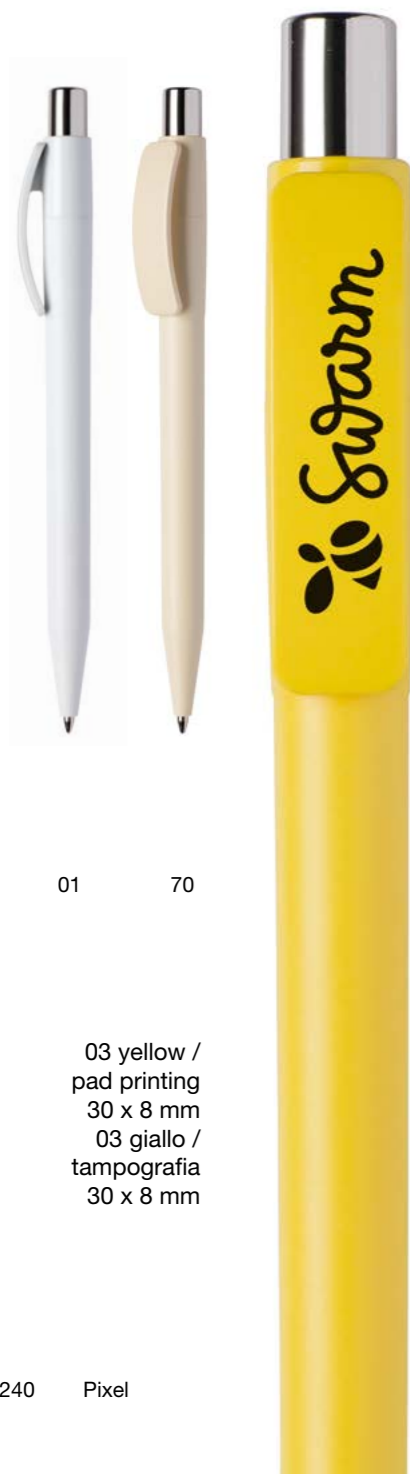

01 70

03 yellow /
pad printing
30 x 8 mm
03 giallo /
tampografia
30 x 8 mm



18 15 74 60 61 71 25

73 brown / pad printing 30 x 8 mm
73 marrone / tampografia 30 x 8 mm



79 09 75

26 aquamarine /
pad printing
30 x 8 mm
26 acquamarina /
tampografia
30 x 8 mm



27



77 12 22 05 04

64 pastel blue / pad printing 60 x 9 mm
64 azzurro pastello / tampografia 60 x 9 mm

PX40 | B

Solid white colour barrel and push-button, solid colours clip, glossy finishes

Fusto e tappino in colore bianco coprente, clip in colori coprenti, finiture lucide



01 03 18 15



74 burgundy / pad printing 30 x 8 mm
74 bordeaux / tampografia 30 x 8 mm



09 12



04

22 blue / pad printing 30 x 8 mm
22 blu / tampografia 30 x 8 mm



PX40 | C

Solid colours with glossy finish
Colori coprenti con finitura lucida



70 03 18 15

09 green / pad printing 30 x 8 mm
09 verde / tampografia 30 x 8 mm



12 22

04 black / pad printing 30 x 8 mm
04 nero / tampografia 30 x 8 mm



PX40 | 30

Transparent colours with glossy finish

Colori trasparenti con finitura lucida



47 aquamarine / pad printing
30 x 8 mm 47 ac-
quamarina /
tampografia
30 x 8 mm



39 52 53 45 51 55 49



44 40

PX40 | FROST NEUTRAL

Transparent colours, matt finish barrel, glossy finish clip and push-button

Colori trasparenti, fusto con finitura satinata, clip e tappino con finitura lucida

The ventilated push-button is compliant with EU laws for small components.



53 orange / pad printing
30 x 8 mm
53 arancio /
tampografia
30 x 8 mm



52



45 51



55 dark violet / pad printing
30 x 8 mm
55 viola scuro /
tampografia
30 x 8 mm



49 47 44 40

Il tappino ventilato è conforme alle normative CEE sui piccoli componenti.

PX40 | FROST

Transparent colours, matt finish barrel, glossy finish clip and push-button



39 52 53 45 59

41 magenta / pad printing 30 x 8 mm
41 magenta / tampografia 30 x 8 mm



31 lilac / pad printing 30 x 8 mm
31 lilla / tampografia 30 x 8 mm

51 55



37 38



49 34 67 44 40 50

78 lime / pad printing 30 x 8 mm
78 lime / tampografia 30 x 8 mm

Colori trasparenti, fusto con finitura satinata, clip e tappino con finitura lucida

PX40 | GOM C CR

Solid colour barrel with rubber finish, solid colour clip with glossy finish, chromed push-button

Fusto in colore coprente gommato, clip in colore coprente con finitura lucida, tappino cromato

15 red / pad printing 30 x 8 mm
15 rosso / tampografia 30 x 8 mm



04 black / pad printing 30 x 8 mm
04 nero / tampografia 30 x 8 mm

PX40 | GOM 30 CR

Solid colour barrel with rubber finish, transparent colour clip with glossy finish, chromed push-button

Fusto in colore coprente gommato, clip in colore trasparente con finitura lucida, tappino cromato

47 aquamarine / pad printing 30 x 8 mm
47 acquamarina / tampografia 30 x 8 mm



41 magenta / pad printing 30 x 8 mm
41 magenta / tampografia 30 x 8 mm

Bay

Casual and attractive
Disinvolta e accattivante

Draws attention
for its simplicity.

*Attrae per la
sua semplicità.*



The entire Maxema collection is available in post-consumer recycled plastic on request /
Tutta la collezione Maxema è realizzabile in plastica riciclata post-consumo su richiesta

Technical information at p. 305
Informazioni tecniche a pag. 305

B500 | MATT BC

Solid white colour barrel,
solid colours cap, matt finishes

Fusto in colore bianco coprente,
cappuccio in colori coprenti,
finiture satinare



70 03 18 15 74

60 pink / pad printing 30 x 7 mm
60 rosa / tampografia 30 x 7 mm



61 71 25 73 79



75 dark green / pad printing 30 x 7 mm
75 verde scuro / tampografia 30 x 7 mm
—
pad printing 60 x 7 mm
tampografia 60 x 7 mm

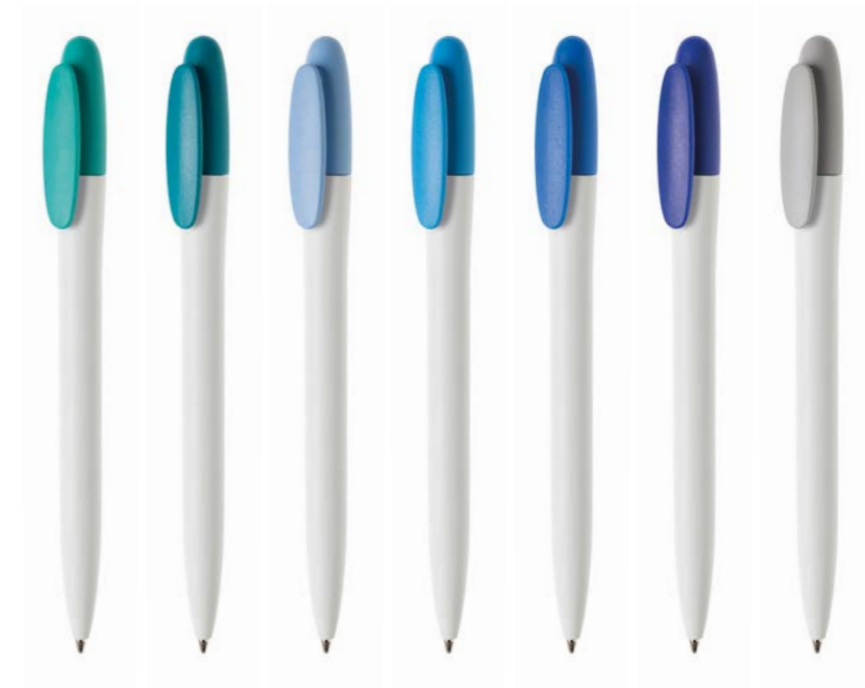

26 27 64 77 12 22 05

04 black / pad printing 60 x 7 mm
04 nero / tampografia 60 x 7 mm



Solid colours with matt finish

Effetto satinato:
raffinata
delicatezza
in 22 colori.

Colori coprenti con finitura satinata

Delicately refined
matt finish in 22
colours.

01 white / pad printing 30 x 7 mm
01 bianco / tampografia 30 x 7 mm



70 03 18 15 74 60 61 71 25

73 brown / pad printing 60 x 7 mm
73 marrone / tampografia 60 x 7 mm



79 09 75 26

27 octan green / pad printing 30 x 7 mm
27 ottanio / tampografia 30 x 7 mm



64 77 12 22 05 04

B500 | BC

Solid white colour barrel,
solid colours cap, glossy finishes

*Fusto in colore bianco coprente,
cappuccio in colori coprenti,
finiture lucide*

B500 | C

Solid colours with glossy finish

Colori coprenti con finitura lucida



03 18 15 25 09 12



Panasonic



04



01 70 03 18 15 74 09 12 22



MANOR

22 blue / pad printing 60 x 7 mm
22 blu / tampografia 60 x 7 mm

04 black / pad printing 30 x 7 mm
04 nero / tampografia 30 x 7 mm

Transparent colours with glossy finish

Colori trasparenti con finitura lucida



39 52 53



45 red /
pad printing
30 x 7 mm
45 rosso /
tampografia
30 x 7 mm



51 55 49



47 aquamarine /
pad printing
30 x 7 mm
47 acquamarina /
tampografia
30 x 7 mm



44 40

Transparent colours with matt finish

Colori trasparenti con finitura satinata

55 dark violet / pad printing 30 x 7 mm
55 viola scuro / tampografia 30 x 7 mm



52 53 45 51



39 neutral / pad printing 60 x 7 mm
39 neutro / tampografia 60 x 7 mm



49 44 40



TAKE IT
SAFE,
TAKE IT
EASY.

ANTIBACTERIAL PENS

Take care of yourself even when you write: the plastic we use for our Antibacterial collection prevents bacteria from settling on pen surfaces and passing from one hand to the other.

—
*Anche quando scrivi,
prenditi cura di te:
la plastica che usiamo
per la nostra collezione
Antibacterial impedisce
ai batteri di depositarsi
sulle superfici della penna
e passare da una mano
all'altra.*

Solo penne, niente batteri

JUST PENS, NO BACTERIA.

EN

We need to feel protected, every day and today even more so. Maxema Antibacterial is our new collection of antibacterial pens, able to combine design and safety. Due to a special ISO 22196:2011 certified antimicrobial additive, the plastic releases silver ions that destroy up to 99,99% of the bacteria present on the pen.

Take it safe, take it easy

In the office, at the bar, in public places: has it ever crossed your mind how many microbes pass from hand to hand through the most everyday actions? Our antibacterial pens, combined with good hygiene habits, guarantee an additional level of protection.

IT

Abbiamo bisogno di sentirci protetti, ogni giorno e oggi ancora di più. Maxema Antibacterial è la nostra nuova collezione di penne antibatteriche, in grado di unire design e sicurezza. La plastica, grazie a uno speciale additivo antimicrobico certificato ISO 22196:2011, rilascia ioni d'argento che distruggono fino al 99,99% dei batteri presenti sulla penna.

Solo penne, niente batteri

In ufficio, al bar, nei luoghi pubblici: hai mai pensato a quanti microbi passano di mano in mano attraverso i gesti più quotidiani? Le nostre penne antibatteriche, abbinate a buone abitudini igieniche, garantiscono un ulteriore livello di protezione.

TAKE IT
SAFE,
TAKE IT
EASY.

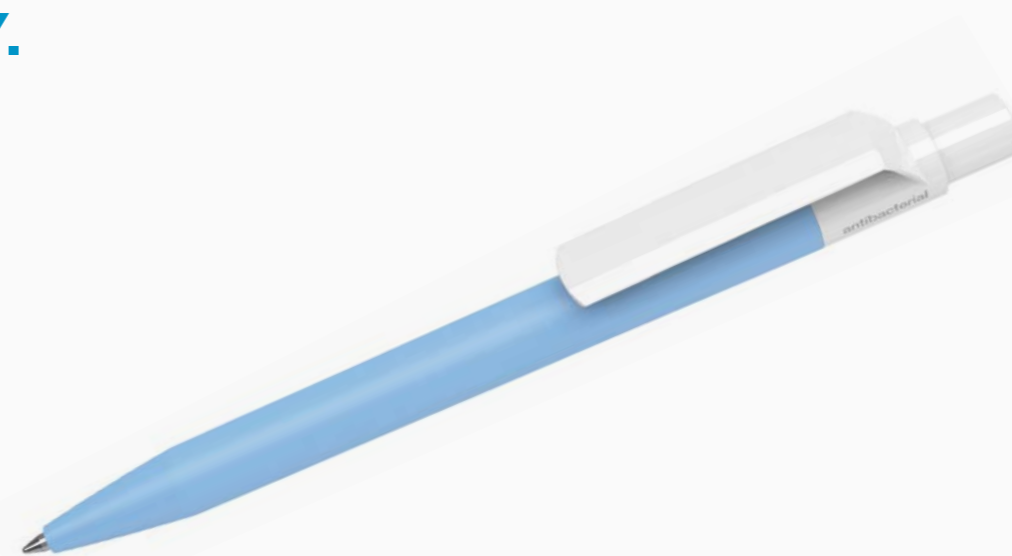

WHY CHOOSE MAXEMA ANTIBACTERIAL



EN

The plastic used is antibacterial

A special ISO 22196:2011 certified antimicrobial additive releases silver ions and prevents bacteria from settling on the surfaces of the pen.

IT

La plastica è antibatterica

Uno speciale additivo antimicrobico certificato ISO 22196:2011 rilascia ioni d'argento e impedisce ai batteri di depositarsi sulle superfici della penna.



Bacteria: up to 99,99% less

Laboratory tests have shown that up to 99,99% of the bacteria on the pen are destroyed.

Batteri: fino al 99,99% in meno

I test condotti in laboratorio dimostrano che i batteri presenti sulla penna vengono distrutti fino al 99,99%.



We care about your health

Some bacteria can cause disease and infections: make your life still safer, even when you write.

Abbiamo a cuore la tua salute

Alcuni batteri possono causare malattie e infezioni: rendi la tua vita ancora più sicura, anche quando scrivi.

SILVER IONS ELIMINATE UP TO 99,99% OF BACTERIA

EN

A special ISO 22196:2011 certified additive that releases silver ions is added to the ABS plastic we use for our Antibacterial pens: the ions settle on the cell walls of bacteria and inhibit their survival and reproduction. The antibacterial effectiveness is confirmed by meticulous evaluation tests.

Microorganisms are inoculated in a sample of material and the surface is covered with a fine sterile film that promotes the spread of the bacteria, prevents evaporation and ensures contact with the antimicrobial surface.

After incubating for 24 hours at 37°C, the microbe concentrations are measured, and the reduction in microorganisms compared to the initial concentrations calculated. The 99,99% reduction in bacteria results in a good antimicrobial effect.

IT

Alla plastica ABS che usiamo per le nostre penne Antibacterial viene aggiunto un particolare additivo antimicrobico certificato ISO 22196:2011 che rilascia ioni d'argento: questi si depositano sulle pareti cellulari dei batteri e ne inibiscono la sopravvivenza e la riproduzione. L'efficacia antibatterica è confermata da accurati test di valutazione.

Su un campione di materiale vengono inoculati i microrganismi e la superficie viene coperta con una sottile pellicola sterile che favorisce la diffusione batterica, ne impedisce l'evaporazione e garantisce il contatto con la superficie antimicrobica.

Dopo l'incubazione per 24 ore a 37°C, vengono misurate le concentrazioni microbiche, calcolando la riduzione dei microrganismi rispetto alle concentrazioni iniziali. La riduzione del 99,99% dei batteri determina un buon effetto antimicrobico.

Test organisms / Organismi di prova	Bacteriostatic activity R / Attività batteriostatica R	Percentage reduction / Riduzione percentuale	Evaluation / Valutazione
Staphylococcus aureus (ATCC 33592)	1	up to 99,99% / fino al 99,99%	Good antimicrobial effect / Buon effetto antimicrobico

DOT ANTIBACTERIAL
D1-MATT CB AB

Antibacterial plastic, solid colour barrel with matt finish, solid glossy white clip, push-button and little sphere



01



15 red / pad printing 40 x 9 mm
15 rosso / tampografia 40 x 9 mm

25 dark violet / pad printing 40 x 9 mm
25 viola scuro / tampografia 40 x 9 mm



Plastica antibatterica, fusto in colore coprente con finitura satinata, clip, tappino e piccola sfera in colore bianco coprente lucido

solid / coprenti

01 white bianco	03 yellow giallo	18 orange arancio	15 red rosso
74 burgundy bordeaux	60 pink rosa	61 magenta magenta	71 light violet viola chiaro
25 dark violet viola scuro	79 lime lime	09 green verde	75 dark green verde scuro
26 aquamarine acquamarina	27 ocean green ottanio	64 pastel blue azzurro pastello	77 cyan ciano
12 light blue azzurro	22 blue blu	05 grey grigio	04 black nero

Technical information at p. 295
Informazioni tecniche a pag. 295

FLOW PURE ANTIBACTERIAL F2P-C AB

Antibacterial plastic, solid white colour
with glossy finish

–
*Plastica antibatterica, colore bianco
coprente con finitura lucida*

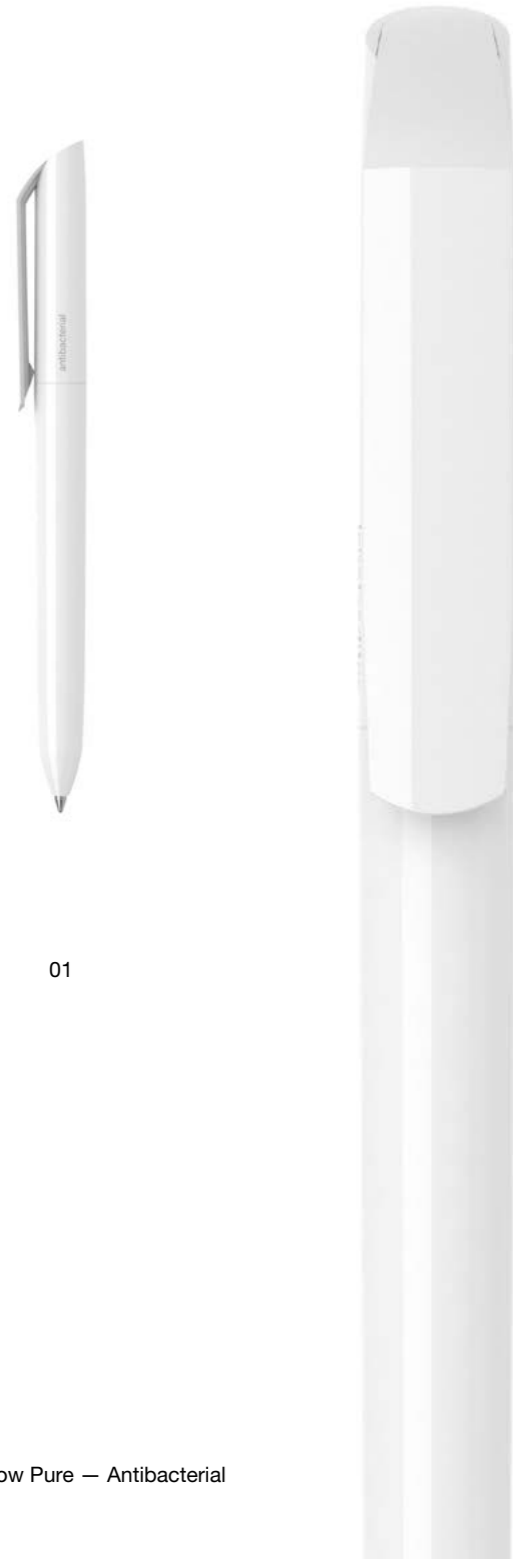

01

solid / coprenti

01
white
bianco

Technical information at p. 293
Informazioni tecniche a pag. 293

ZINK ANTIBACTERIAL Z1-C AB

Antibacterial plastic, solid white colour
with glossy finish

–
*Plastica antibatterica, colore bianco
coprente con finitura lucida*

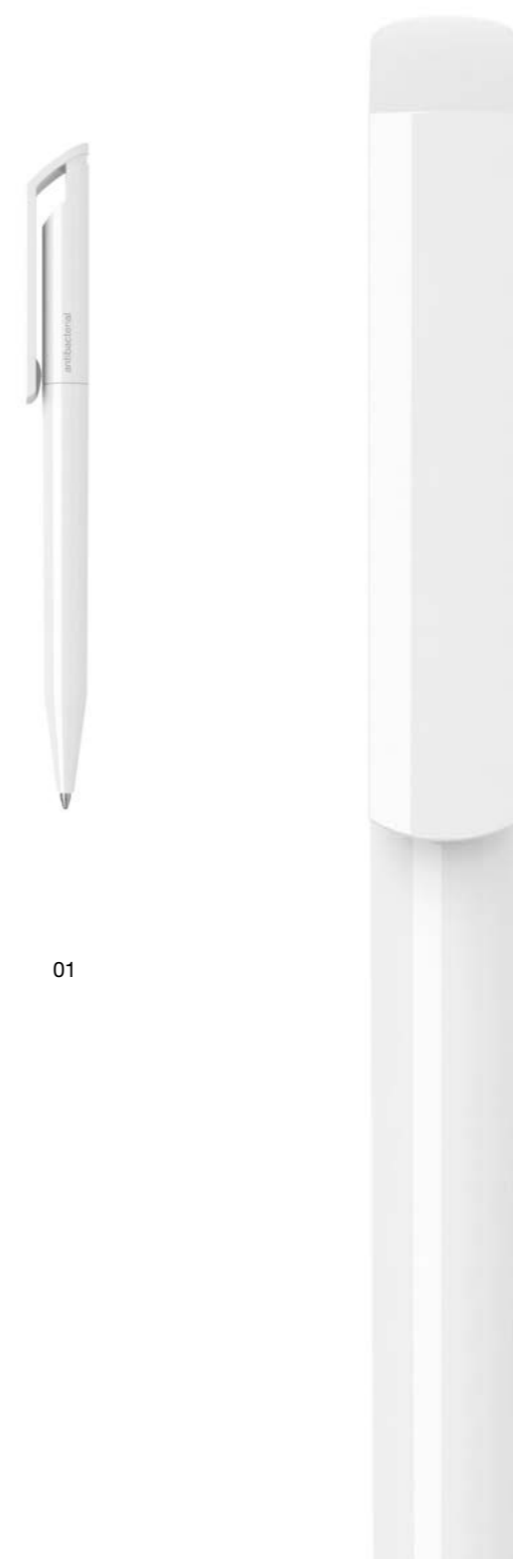

01

solid / coprenti

01
white
bianco

Technical information at p. 296
Informazioni tecniche a pag. 296

PIXEL ANTIBACTERIAL
PX40-MATT CB AB

Antibacterial plastic, solid white colour
barrel with matt finish, solid glossy
white clip and push-button

–
*Plastica antibatterica, fusto in colore
bianco coprente con finitura
satinata, clip e tappino in colore
bianco coprente lucido*



01



solid / coprenti

01
white
bianco

Technical information at p. 304
Informazioni tecniche a pag. 304

BAY ANTIBACTERIAL
B500-C AB

Antibacterial plastic, solid white colour
with glossy finish

–
*Plastica antibatterica, colore bianco
coprente con finitura lucida*



01



solid / coprenti

01
white
bianco

Technical information at p. 305
Informazioni tecniche a pag. 305

Tag green

Objective: total safety.
Obiettivo: sicurezza totale.

Design that combines
safety and environment
friendliness.

*Il design sposa
la sicurezza e rispetta
l'ambiente.*

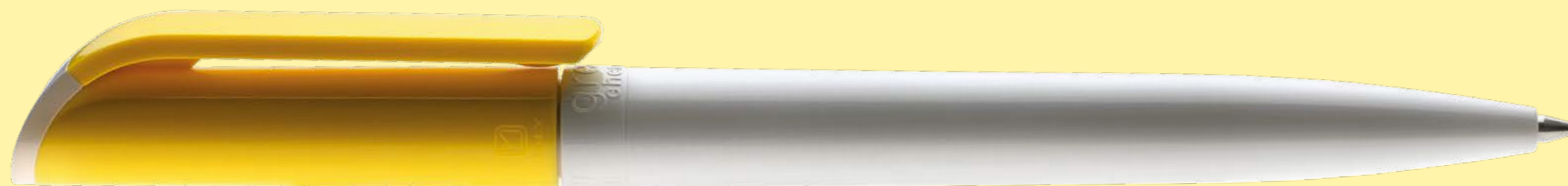

Technical information at p. 300
Informazioni tecniche a pag. 300

Made from a special plastic, suitable for use in toy manufacture.

Realizzata con plastica idonea alla produzione dei giocattoli.



Looking to the future Guarda al futuro

Made of plastic suitable for toy manufacture (according to European standard EN 71-03 and U.S. FDA regulations).

Prodotta con plastica idonea all'utilizzo nei giocattoli (direttiva europea EN 71 - 03 e direttiva americana FDA).



Antibacterial Antibatterica

It is made of antibacterial plastic containing a special additive which releases silver ions that prevent bacteria from colonising the surface of the pen.

La plastica è antibatterica, grazie ad uno speciale additivo che sprigiona ioni d'argento impedendo ai batteri di depositarsi sulle superfici della penna.



Really safe Buona davvero

The plastics employed are compliant with European and American FDA food contact regulations.

Le plastiche utilizzate sono conformi alla normativa europea e americana FDA per il contatto alimentare.



Nature friendly Vicina all'ambiente

Made of non-toxic plastics, it has been designed to have a long life and to minimise the risk of harmful substances being released into the environment. Using a pen for as long as possible helps to reduce pollution and enables us to give full expression to the concept of promotion.

Realizzata con materiali atossici, è stata progettata per durare a lungo nel tempo. Una penna che dura di più inquina di meno perchè rimane a lungo nelle nostre mani, massimizzando la diffusione del logo o del messaggio che porta con sé.



CLP compliant Conforme alle regole

It is rated as non hazardous pursuant to the Regulation on Classification, Labelling and Packaging.

La plastica non risulta pericolosa per il CLP (classification, labeling and packaging).



Green Chemical

It does not contain dioxin, phthalates, bisphenol A, antimony, arsenic, barium, cadmium, chrome, mercury, lead, polybrominated biphenyls (PBBs), polybrominated diphenyl ethers (PBDEs) or deca-BDE, and conforms to RoHS and REACH directives.

Non contiene: diossina, ftalati, bisfenolo A, antimonio, arsenico, bario, cadmio, cromo, mercurio, piombo, ed è conforme alle normative RoHS e REACH. Bifenili polibromurati (PBB), eteri di difenile (PBDE) e deca BDE sono completamente assenti, ed è conforme alle normative RoHS e REACH.



TA2 | B

Solid white colour barrel and clip,
solid colours upper plug,
glossy finishes

*Fusto e clip in colore bianco
coprente, tassello superiore in colori
coprenti, finiture lucide*

Green Chemical
plastic releases
silver ions that
have an anti-
bacterial function.



42 43 35 13 29 65 77 54 04

01 white / pad printing 40 x 9 mm
01 bianco / tampografia 40 x 9 mm

TA2 | BC

Solid white colour barrel and upper
plug, solid colours clip,
glossy finishes

*Fusto e tassello superiore in colore
bianco coprente, clip in colori
coprenti, finiture lucide*

La plastica Green
Chemical sprigiona
ioni d'argento che
svolgono una
funzione antibatterica.



42 43 35 13 65 77 04

29 green / pad printing 40 x 9 mm
29 verde / tampografia 40 x 9 mm

54 blue /
pad printing
40 x 9 mm
54 blu /
tampografia
40 x 9 mm

Icon green

People and environment friendly.
Nel rispetto dell'uomo e della natura.

Testimony of an
enduring message.

*Testimone di un
messaggio destinato
a durare nel tempo.*



Technical information at p. 301
Informazioni tecniche a pag. 301

A significant step forward toward the use of safe plastic.

Un significativo passo avanti nella sicurezza della plastica.



Nature friendly Vicina all'ambiente

Made of non-toxic plastics, it has been designed to have a long life and to minimise the risk of harmful substances being released into the environment. Using a pen for as long as possible helps to reduce pollution and enables us to give full expression to the concept of promotion.

Realizzata con materiali atossici, è stata progettata per durare a lungo nel tempo. Una penna che dura di più inquina di meno perchè rimane a lungo nelle nostre mani, massimizzando la diffusione del logo o del messaggio che porta con sé.



Green Chemical

It does not contain dioxin, phthalates, bisphenol A, antimony, arsenic, barium, cadmium, chrome, mercury, lead, polybrominated biphenyls (PBBs), polybrominated diphenyl ethers (PBDEs) or deca-BDE, and conforms to RoHS and REACH directives.

Non contiene: diossina, ftalati, bisfenolo A, antimonio, arsenico, bario, cadmio, cromo, mercurio, piombo, ed è conforme alle normative RoHS e REACH. Bifenili polibromurati (PBB), eteri di difenile (PBDE) e deca BDE sono completamente assenti, ed è conforme alle normative RoHS e REACH.



Looking to the future Guarda al futuro

Made of plastic suitable for toy manufacture (according to European standard EN 71-03 and U.S. FDA regulations).

Prodotta con plastica idonea all'utilizzo nei giocattoli (direttiva europea EN 71 - 03 e direttiva americana FDA).



Antibacterial Antibatterica

It is made of antibacterial plastic containing a special additive which releases silver ions that prevent bacteria from colonising the surface of the pen.

La plastica è antibatterica, grazie ad uno speciale additivo che sprigiona ioni d'argento impedendo ai batteri di depositarsi sulle superfici della penna.



Really safe Buona davvero

The plastics employed are compliant with European and American FDA food contact regulations.

Le plastiche utilizzate sono conformi alla normativa europea e americana FDA per il contatto alimentare.



CLP compliant Conforme alle regole

It is rated as non hazardous pursuant to the Regulation on Classification, Labelling and Packaging.

La plastica non risulta pericolosa per il CLP (classification, labeling and packaging).

IG2 | BC

Solid white colour barrel,
solid colours cap, glossy finishes

*Fusto in colore bianco coprente,
cappuccio in colori coprenti,
finiture lucide*

Made of special
plastic used
to manufacture
children's toys.

35 red /
pad printing 35 x 7 mm
35 rosso /
tampografia 35 x 7 mm



42

43



13



65



54



04

29 green / pad printing 35 x 7 mm
29 verde / tampografia 35 x 7 mm

IG2 | C

Solid colours with glossy finish

Colori solidi con finitura lucida

Realizzata con
una plastica
speciale idonea
alla produzione
di giocattoli.

01 white / pad printing 35 x 7 mm
01 bianco / tampografia 35 x 7 mm



70



42



43



35



13



29

65 dark green / pad printing 35 x 7 mm
65 verde scuro / tampografia 35 x 7 mm



54



04

Kind R-PET

NEW

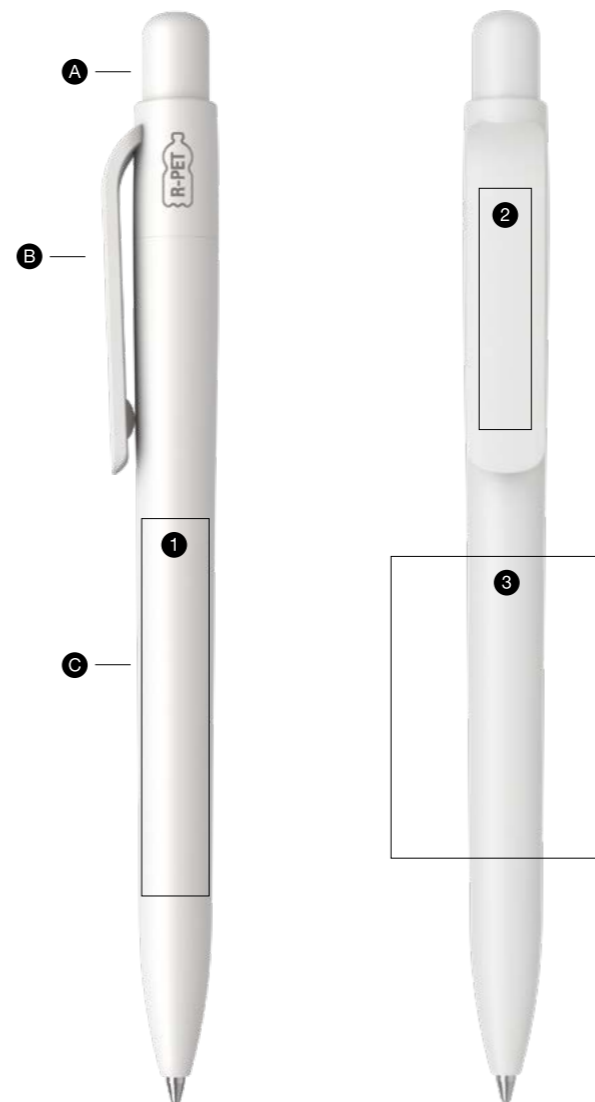

Components / Componenti

- Ⓐ Push-button / *tappino*
- Ⓑ Clip
- Ⓒ Barrel / *fusto*

Print area / Area stampabile

- ① pad printing / *tampografia*
50 x 9 mm
- ② pad printing / *tampografia*
32 x 7 mm
- ③ screen printing / *serigrafia*
40 x 30 mm

Features / Caratteristiche

retractable /
meccanismo a scatto

made of certified R-PET derived
from the recycling of plastic bottles
*/ realizzata in R-PET certificato,
derivante dal riciclo di bottiglie
di plastica*

Jumbo refill, blue and black ink /
refill Jumbo, inchiostro blu e nero

the barrel is available in matt and
rubber finishes, the clip and the push-
button are available in matt finish /
*il fusto è disponibile con superfici
satinato e gommato, la clip e il tappino
sono disponibili con superfici satinato*



R-PET PLASTIC / *PLASTICA R-PET*

Small imperfections and slight colour variations
are to be considered intrinsic features of the
reuse of recycled PET material. /
*Piccole imperfezioni e lievi variazioni cromatiche
sono da considerarsi caratteristiche intrinseche
del riutilizzo del materiale PET riciclato.*

Tag green Post-consumer Recycled Antibacterial

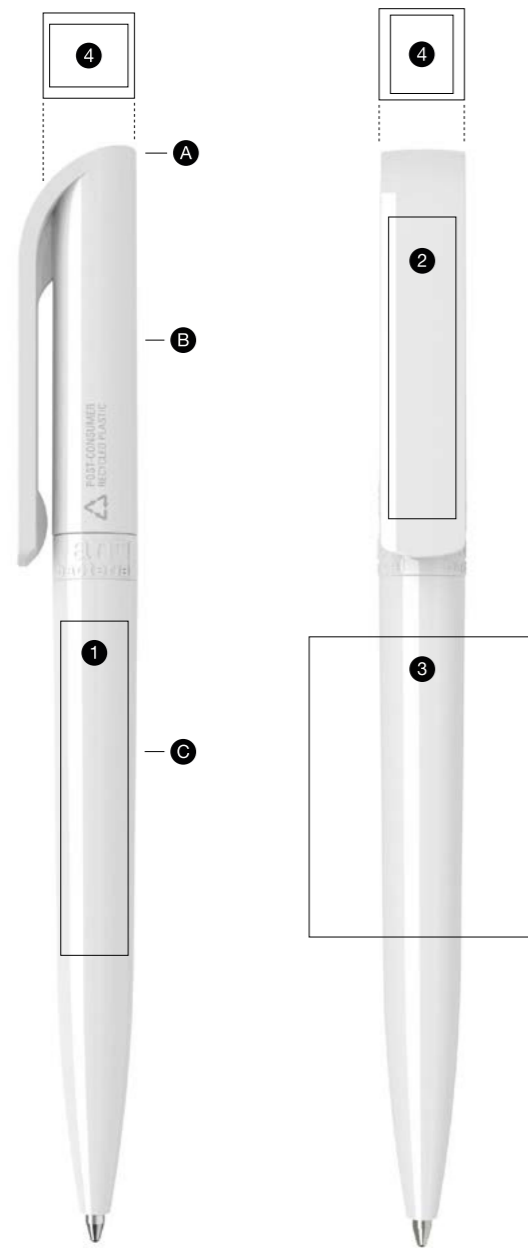

Components / Componenti

- A Plug / tassello
- B Clip / clip
- C Barrel / fusto

Print area / Area stampabile

- 1 pad printing / tampografia 45 x 9 mm
- 2 pad printing / tampografia 40 x 9 mm
- 3 screen printing / serigrafia 40 x 30 mm
- 4 pad printing / tampografia 8 x 10 mm

Features / Caratteristiche

twist-action / meccanismo a rotazione

recycled plastic derived from post-consumer products, certified and compliant with RoHS and REACH regulations / plastica riciclata derivante da prodotti post-consumo certificata e conforme alle normative RoHS e REACH.

ISO 22196:2011 certified antimicrobial additive / additivo antimicrobico certificato ISO 22196:2011

Jumbo refill, blue and black ink / refill Jumbo, inchiostro blu e nero

available in glossy finish / disponibile con superfici lucide



The entire Maxema collection is available in post-consumer recycled plastic on request / Tutta la collezione Maxema è realizzabile in plastica riciclata post-consumo su richiesta

TAKE IT SAFE, TAKE IT EASY.

Tag green is available in antibacterial plastic / La penna Tag green è disponibile in plastica antibatterica

Icon green Post-consumer Recycled Antibacterial

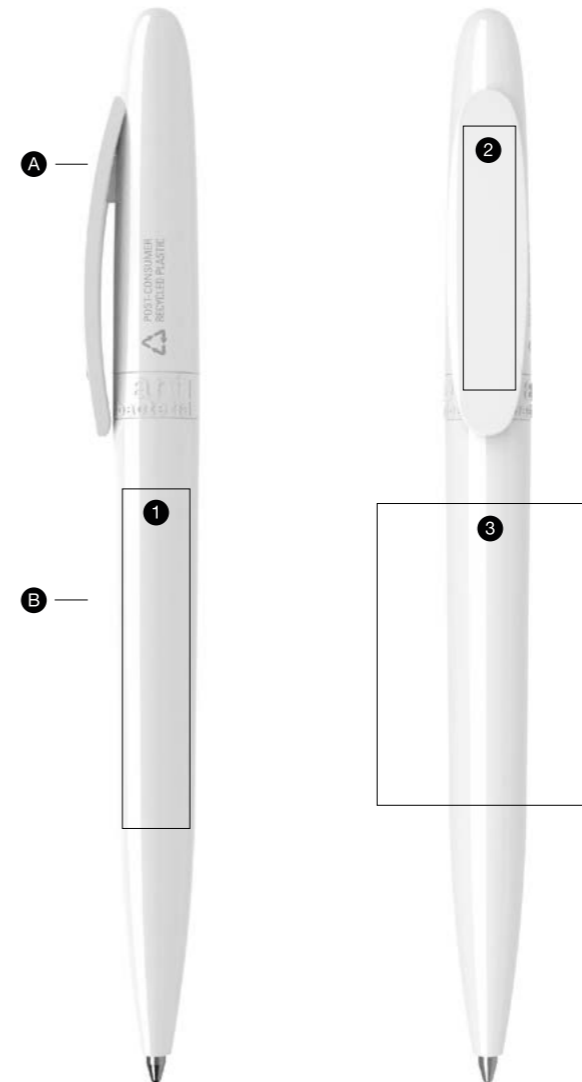

Components / Componenti

- A Cap / cappuccio
- B Barrel / fusto

Print area / Area stampabile

- 1 pad printing / tampografia 45 x 9 mm
- 2 pad printing / tampografia 35 x 7 mm
- 3 screen printing / serigrafia 40 x 30 mm

Features / Caratteristiche

twist-action / meccanismo a rotazione

recycled plastic derived from post-consumer products, certified and compliant with RoHS and REACH regulations / plastica riciclata derivante da prodotti post-consumo certificata e conforme alle normative RoHS e REACH.

ISO 22196:2011 certified antimicrobial additive / additivo antimicrobico certificato ISO 22196:2011

Jumbo refill, blue and black ink / refill Jumbo, inchiostro blu e nero

available in glossy finish / disponibile con superfici lucide



The entire Maxema collection is available in post-consumer recycled plastic on request / Tutta la collezione Maxema è realizzabile in plastica riciclata post-consumo su richiesta

TAKE IT SAFE, TAKE IT EASY.

Icon green is available in antibacterial plastic / La penna Icon green è disponibile in plastica antibatterica

Mood Metal



Components / Componenti

- A Push-button / tappino
- B Clip
- C Barrel / fusto
- D Tip / punta

Print area / Area stampabile

- 1 laser engraving 30 x 7 mm
incisione laser 30 x 7 mm
- 2 pad printing / tampografia
40 x 9 mm

Features / Caratteristiche

retractable with return spring /
meccanismo a scatto, con molla
di ritorno

metal push-button, barrel and tip,
individually processed with diamond
mirror face finish / tappino, fusto e
punta in metallo, lavorati singolarmente
con finitura a specchio diamantata

clip made of non-toxic, highly resistant
ABS plastic / clip realizzata in plastica
ABS atossica e ad alta resistenza

“Parker type” refill, blue and black ink /
refill “tipo Parker”, inchiostro blu e nero

Fast Dry Gel blue and black ink available
on request /
Refill Gel Fast Dry blu e nero disponibile
su richiesta



The entire Maxema collection is available
in post-consumer recycled plastic on request /
Tutta la collezione Maxema è realizzabile
in plastica riciclata post-consumo su richiesta

Mood

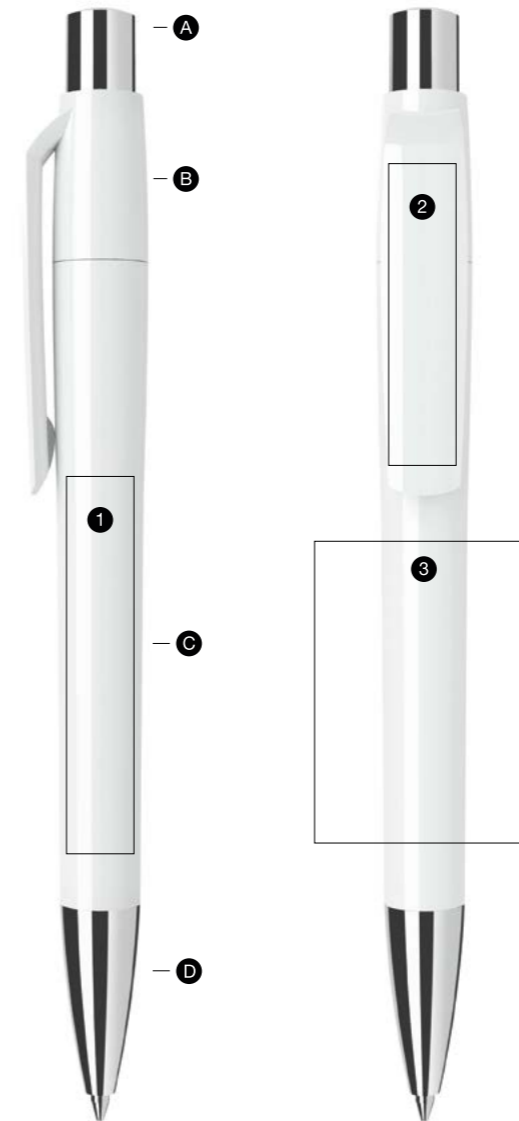

Components / Componenti

- A Push-button / tappino
- B Clip
- C Barrel / fusto
- D Tip / punta

Print area / Area stampabile

- 1 pad printing / tampografia
46 x 9 mm
- 2 pad printing / tampografia
40 x 9 mm
- 3 screen printing / serigrafia
40 x 30 mm

Features / Caratteristiche

retractable with return spring /
meccanismo a scatto, con molla
di ritorno

made of non-toxic, highly resistant
ABS plastic / realizzata in plastica ABS
atossica e ad alta resistenza

metal tip and push-button,
individually processed with diamond
mirror face finish / tappino e punta in
metallo, lavorati singolarmente con
finitura a specchio diamantata

“Parker type” refill, blue and black ink /
refill “tipo Parker”, inchiostro blu e nero

available in glossy or rubberised finish /
disponibile con superfici lucide
o gommate

rubberised barrel versions are only
printable on the clip / le versioni con
fusto gommato sono stampabili solo
su clip

Fast Dry Gel blue and black ink available
on request /
Refill Gel Fast Dry blu e nero disponibile
su richiesta



The entire Maxema collection is available
in post-consumer recycled plastic on request /
Tutta la collezione Maxema è realizzabile
in plastica riciclata post-consumo su richiesta

Icon Pure

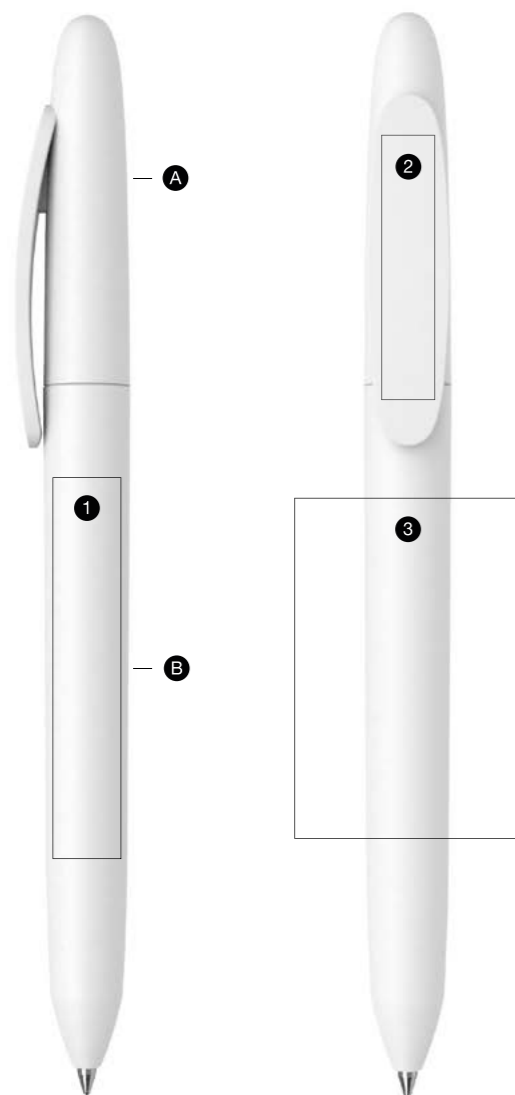

Components / Componenti

- A** Cap / cappuccio
- B** Barrel / fusto

Print area / Area stampabile

- 1** pad printing / tampografia 50 x 9 mm
- 2** pad printing / tampografia 35 x 7 mm
- 3** screen printing / serigrafia 45 x 30 mm

Features / Caratteristiche

twist-action / meccanismo a rotazione

made of non-toxic highly resistant ABS plastic / realizzata in plastica ABS, atossica e ad alta resistenza

Jumbo refill, blue and black ink / refill Jumbo, inchiostro blu e nero

available in rubberised and matt recycled finish / disponibile con superfici gommate e satinare riciclate

printing must be carried out before rubber coating or, alternatively, using specific inks for rubberised surfaces / la stampa deve essere eseguita prima della gommatura o, in alternativa, con inchiostri specifici per superfici gommate

IC8 — POST-CONSUMER RECYCLED PLASTIC / PLASTICA RICICLATA POST-CONSUMO

Small imperfections and slight colour variations are to be considered intrinsic features of the recycled material deriving from the post-consumer sector. / Piccole imperfezioni e lievi variazioni cromatiche sono da considerarsi caratteristiche intrinseche del materiale riciclato derivante dal post-consumo.

Fast Dry Gel blue and black ink available on request /
Refill Gel Fast Dry blu e nero disponibile su richiesta



The entire Maxema collection is available in post-consumer recycled plastic on request /
Tutta la collezione Maxema è realizzabile in plastica riciclata post-consumo su richiesta

Flow Pure

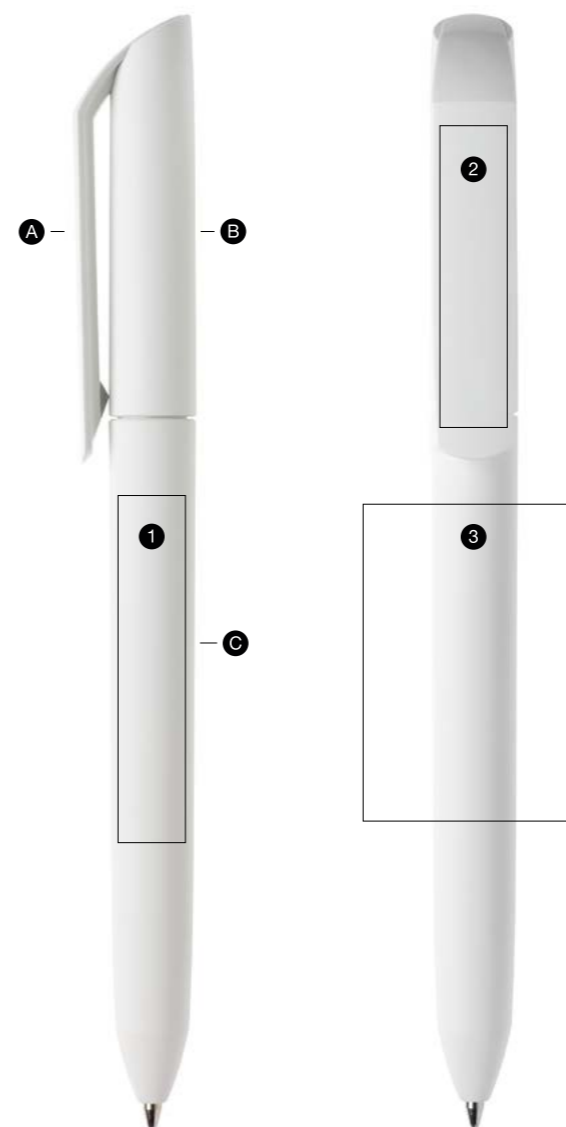

Components / Componenti

- A** Clip
- B** Cap / cappuccio
- C** Barrel / fusto

Print area / Area stampabile

- 1** pad printing / tampografia 50 x 9 mm
- 2** pad printing / tampografia 40 x 9 mm
- 3** screen printing / serigrafia 45 x 30 mm

Features / Caratteristiche

twist-action / meccanismo a rotazione

made of non-toxic highly resistant ABS plastic / realizzata in plastica ABS, atossica e ad alta resistenza

Jumbo refill, blue and black ink / refill Jumbo, inchiostro blu e nero

available in glossy, matt or rubberised finish / disponibile con superfici lucide, satinare o gommate

F2P — POST-CONSUMER RECYCLED PLASTIC / PLASTICA RICICLATA POST-CONSUMO

Small imperfections and slight colour variations are to be considered intrinsic features of the recycled material deriving from the post-consumer sector. / Piccole imperfezioni e lievi variazioni cromatiche sono da considerarsi caratteristiche intrinseche del materiale riciclato derivante dal post-consumo.



The entire Maxema collection is available in post-consumer recycled plastic on request /
Tutta la collezione Maxema è realizzabile in plastica riciclata post-consumo su richiesta

TAKE IT SAFE, TAKE IT EASY.

Flow Pure is available in white antibacterial plastic /
La penna Flow Pure è disponibile in plastica antibatterica bianca

Fast Dry Gel blue and black ink available on request /
Refill Gel Fast Dry blu e nero disponibile su richiesta

Flow

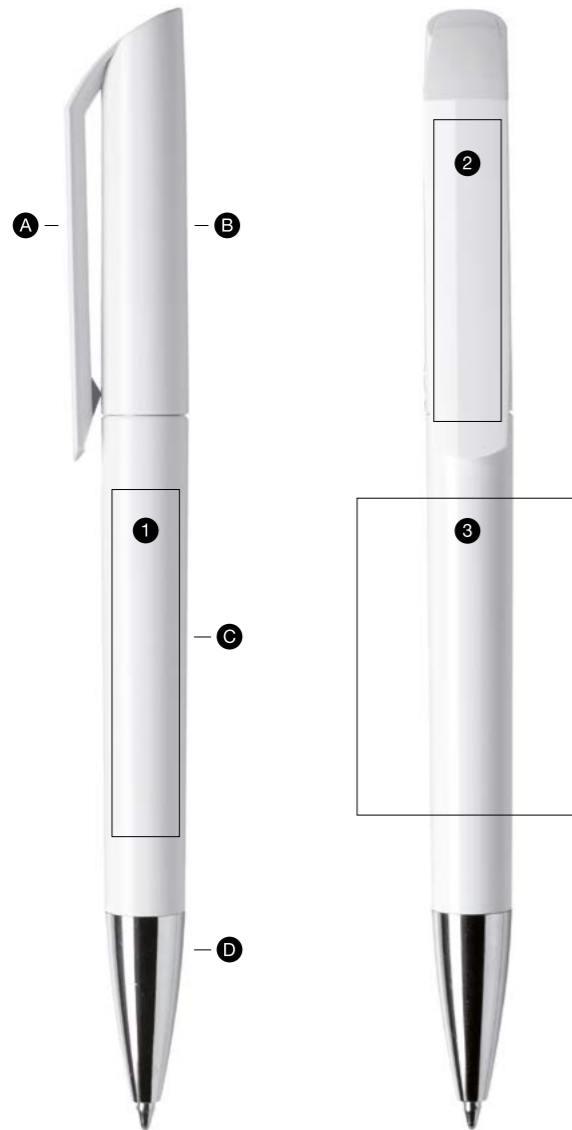

Components / Componenti

- A Clip
- B Cap / cappuccio
- C Barrel / fusto
- D Tip / punta

Print area / Area stampabile

- 1 pad printing / tampografia
46 x 9 mm
- 2 pad printing / tampografia
40 x 9 mm
- 3 screen printing / serigrafia
42 x 30 mm

Features / Caratteristiche

twist-action / meccanismo a rotazione

made of non-toxic highly resistant ABS plastic / realizzata in plastica ABS, atossica e ad alta resistenza

galvanic process used to chrome tip / la cromatura della punta è ottenuta con trattamento galvanico

Jumbo refill, blue and black ink / refill Jumbo, inchiostro blu e nero

available in glossy, matt or rubberised finish / disponibile con superfici lucide, satinare o gommate

in the Texture version, the entire matt cap features a honeycomb design / nella versione Texture il cappuccio satinato è percorso interamente da una trama a nido d'ape

Fast Dry Gel blue and black ink available on request /
Refill Gel Fast Dry blu e nero disponibile su richiesta



The entire Maxema collection is available in post-consumer recycled plastic on request /
Tutta la collezione Maxema è realizzabile in plastica riciclata post-consumo su richiesta

Dot

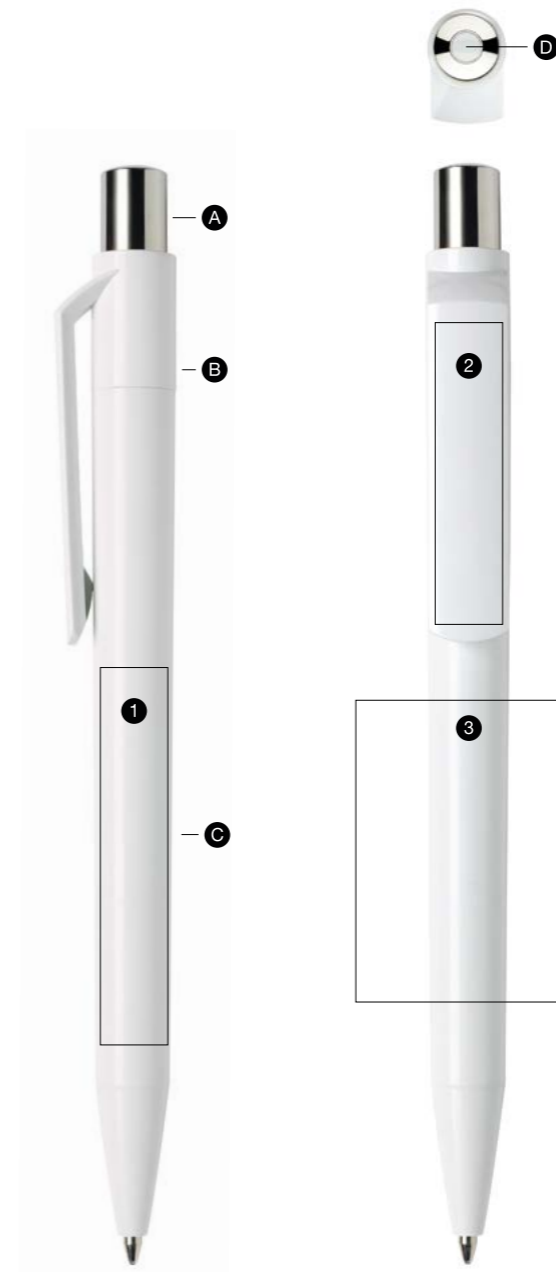

Components / Componenti

- A Push-button / tappino
- B Clip
- C Barrel / fusto
- D Little sphere / piccola sfera

Print area / Area stampabile

- 1 pad printing / tampografia
50 x 9 mm
- 2 pad printing / tampografia
40 x 9 mm
- 3 screen printing / serigrafia
40 x 30 mm

Features / Caratteristiche

retractable with return spring / meccanismo a scatto, con molla di ritorno

made of non-toxic, highly resistant ABS plastic / realizzata in plastica ABS atossica e ad alta resistenza

galvanic process used to chrome and gold ABS push-button / la cromatura e la doratura del tappino sono ottenute con trattamento galvanico

Jumbo refill, blue and black ink / refill Jumbo, inchiostro blu e nero

available in glossy, matt or rubberised finish / disponibile con superfici lucide, satinare o gommate

rubberised barrel versions are only printable on the clip / le versioni con fusto gommato sono stampabili solo su clip

D1 – RECYCLED PLASTIC
PLASTICA RICICLATA

Small imperfections and slight colour variations are to be considered intrinsic features of the recycled material deriving from the post-consumer sector. / Piccole imperfezioni e lievi variazioni cromatiche sono da considerarsi caratteristiche intrinseche del materiale riciclato derivante dal post-consumo.

Fast Dry Gel blue and black ink available on request /
Refill Gel Fast Dry blu e nero disponibile su richiesta



The entire Maxema collection is available in post-consumer recycled plastic on request /
Tutta la collezione Maxema è realizzabile in plastica riciclata post-consumo su richiesta

TAKE IT SAFE, TAKE IT EASY.

Dot is available in coloured antibacterial plastic /
La penna Dot è disponibile in plastica antibatterica colorata

Zink

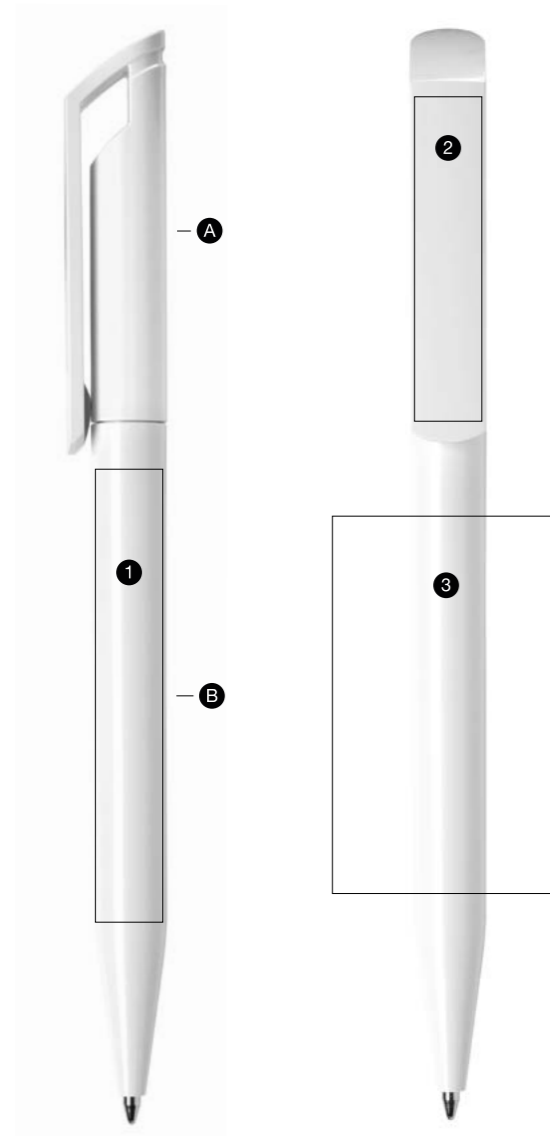

Components / Componenti

- A Cap / cappuccio
- B Barrel / fusto

Print area / Area stampabile

- 1 pad printing / tampografia 60 x 9 mm
- 2 pad printing / tampografia 43 x 9 mm
- 3 screen printing / serigrafia 50 x 30 mm

Features / Caratteristiche

twist-action / meccanismo a rotazione

made of non-toxic, highly resistant ABS plastic / realizzata in plastica ABS atossica e ad alta resistenza

Jumbo refill, blue and black ink / refill Jumbo, inchiostro blu e nero

available in glossy finish / disponibile con superfici lucide

 Z1 — RECYCLED PLASTIC
PLASTICA RICICLATA

Small imperfections and slight colour variations are to be considered intrinsic features of the recycled material deriving from the post-consumer sector. / Piccole imperfezioni e lievi variazioni cromatiche sono da considerarsi caratteristiche intrinseche del materiale riciclato derivante dal post-consumo.

Fast Dry Gel blue and black ink available on request /
Refill Gel Fast Dry blu e nero disponibile su richiesta



The entire Maxema collection is available in post-consumer recycled plastic on request / Tutta la collezione Maxema è realizzabile in plastica riciclata post-consumo su richiesta

TAKE IT SAFE, TAKE IT EASY.

Zink is available in white antibacterial plastic / La penna Zink è disponibile in plastica antibatterica bianca

View

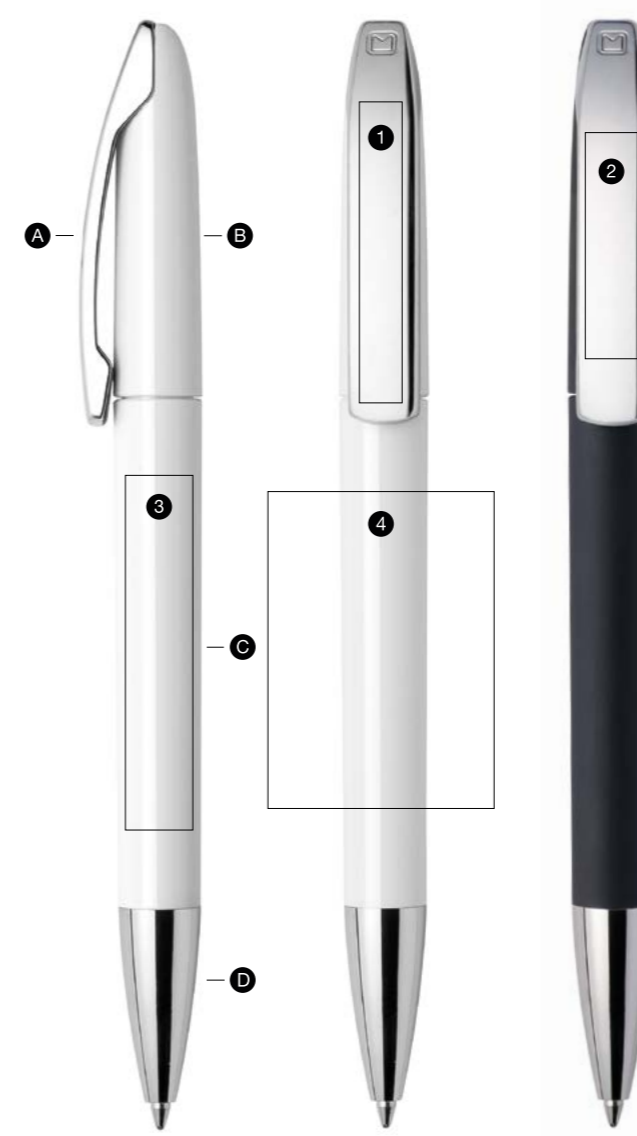

Components / Componenti

- A Clip
- B Cap / cappuccio
- C Barrel / fusto
- D Punta / tip

Print area / Area stampabile

- 1 pad printing / tampografia 40 x 6 mm
- 2 laser engraving 30 x 7 mm
incisione laser 30 x 7 mm
- 3 pad printing / tampografia 47 x 9 mm
- 4 screen printing / serigrafia 42 x 30 mm

Features / Caratteristiche

twist-action / meccanismo a rotazione

made of non-toxic, highly resistant ABS plastic / realizzata in plastica ABS atossica e ad alta resistenza

metal chrome finish clip available for laser engraving and pad printing / clip in metallo cromato, disponibile per incisione laser e tampografia

galvanic process used to chrome tip / la cromatura della punta è ottenuta con trattamento galvanico

Jumbo refill, blue and black ink / refill Jumbo, inchiostro blu e nero

available in glossy, rubberised or aluminium painted finish / disponibile con superfici lucide, gommate o verniciate in colore alluminio

Fast Dry Gel blue and black ink available on request /
Refill Gel Fast Dry blu e nero disponibile su richiesta



The entire Maxema collection is available in post-consumer recycled plastic on request / Tutta la collezione Maxema è realizzabile in plastica riciclata post-consumo su richiesta

Tag

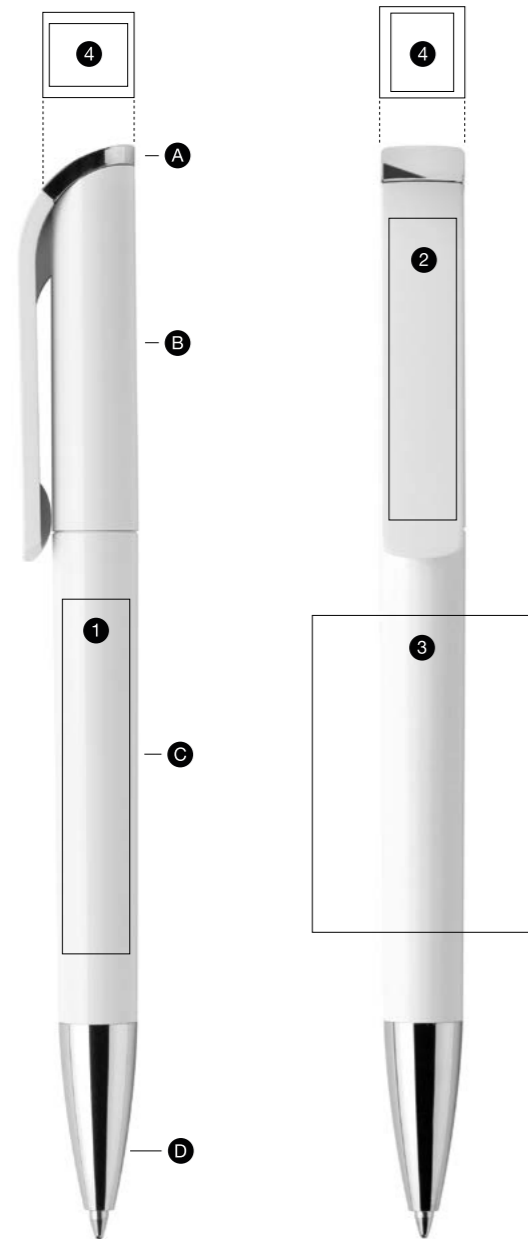

Components / Componenti

- A Plug / tassello
- B Clip / clip
- C Barrel / fusto
- D Tip / punta

Print area / Area stampabile

- 1 pad printing / tampografia
47 x 9 mm
- 2 pad printing / tampografia
40 x 9 mm
- 3 screen printing / serigrafia
42 x 30 mm
- 4 pad printing / tampografia
8 x 10 mm

Features / Caratteristiche

twist-action / meccanismo a rotazione

made of non-toxic, highly resistant
ABS plastic / realizzata in plastica ABS
atossica e ad alta resistenza

galvanic process used to chrome tip
and upper plug / la cromatura della
punta e del tassello superiore
è ottenuta con trattamento galvanico

Jumbo refill, blue and black ink /
refill Jumbo, inchiostro blu e nero

available in glossy, matt and metallic
or aluminium painted finish /
disponibile con superfici lucide,
satinare o verniciate con colori
metallizzati o alluminio

Fast Dry Gel blue and black ink available
on request /
Refill Gel Fast Dry blu e nero disponibile
su richiesta



The entire Maxema collection is available
in post-consumer recycled plastic on request /
Tutta la collezione Maxema è realizzabile
in plastica riciclata post-consumo su richiesta

Icon

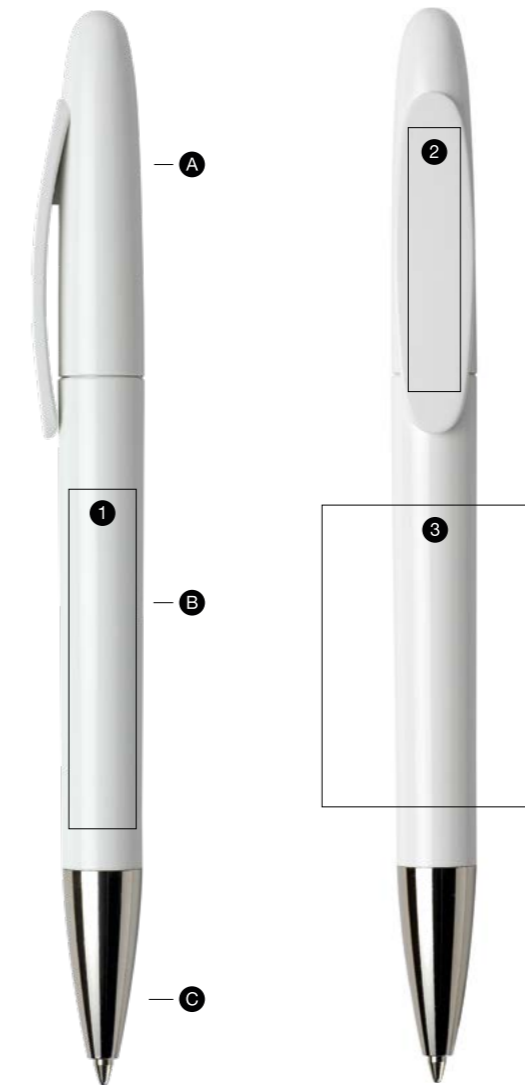

Components / Componenti

- A Cap / cappuccio
- B Barrel / fusto
- C Tip / punta

Print area / Area stampabile

- 1 pad printing / tampografia
45 x 9 mm
- 2 pad printing / tampografia
35 x 7 mm
- 3 screen printing / serigrafia
40 x 30 mm

Features / Caratteristiche

twist-action / meccanismo a rotazione

made of non-toxic, highly resistant
ABS plastic / realizzata in plastica ABS,
atossica e ad alta resistenza

galvanic process used to chrome and
gild ABS tip / la cromatura e la doratura
della punta in ABS sono ottenute
con trattamento galvanico

Jumbo refill, blue and black ink / refill
Jumbo, inchiostro blu e nero

available in glossy, matt and metallic
or aluminium painted finish / disponibile
con superfici lucide, satinare
o verniciate in colori metallizzati
o alluminio

Fast Dry Gel blue and black ink available
on request /
Refill Gel Fast Dry blu e nero disponibile
su richiesta



The entire Maxema collection is available
in post-consumer recycled plastic on request /
Tutta la collezione Maxema è realizzabile
in plastica riciclata post-consumo su richiesta

Tag green

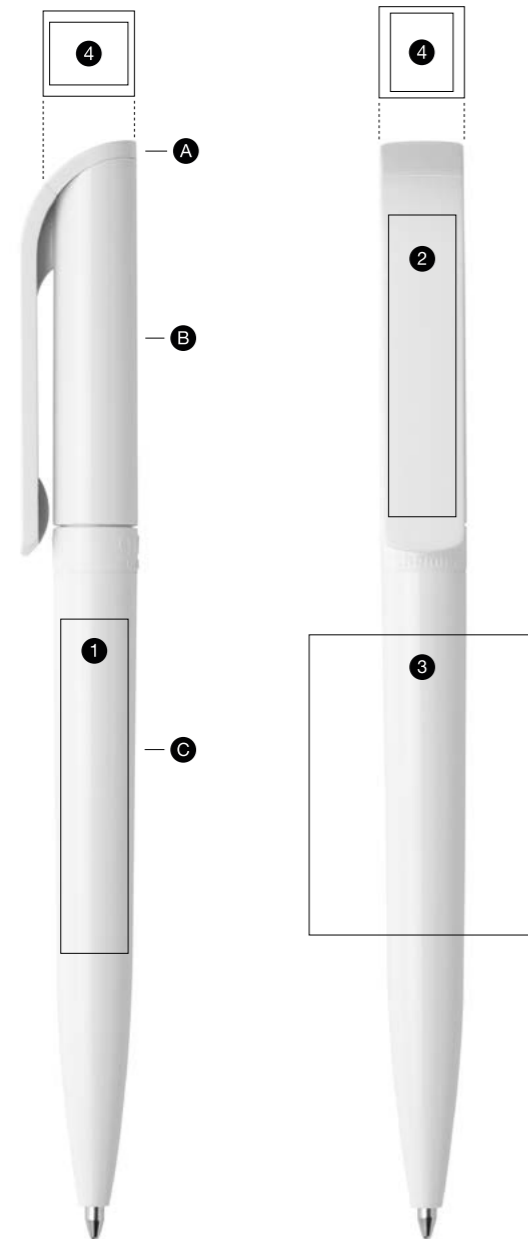

Components / Componenti

- A Plug / tassello
- B Clip / clip
- C Barrel / fusto

Print area / Area stampabile

- 1 pad printing / tampografia
45 x 9 mm
- 2 pad printing / tampografia
40 x 9 mm
- 3 screen printing / serigrafia
40 x 30 mm
- 4 pad printing / tampografia
8 x 10 mm

Features / Caratteristiche

twist-action / meccanismo a rotazione

made of non-toxic, highly resistant special ABS plastic certified for use in toy manufacture / realizzata in plastica ABS speciale, ad alta resistenza, atossica e certificata per l'utilizzo nei giocattoli

antibacterial / antibatterico

X20 refill, blue and black ink / refill X-20, inchiostro blu e nero

available in glossy finish / disponibile con superfici lucide

Icon green

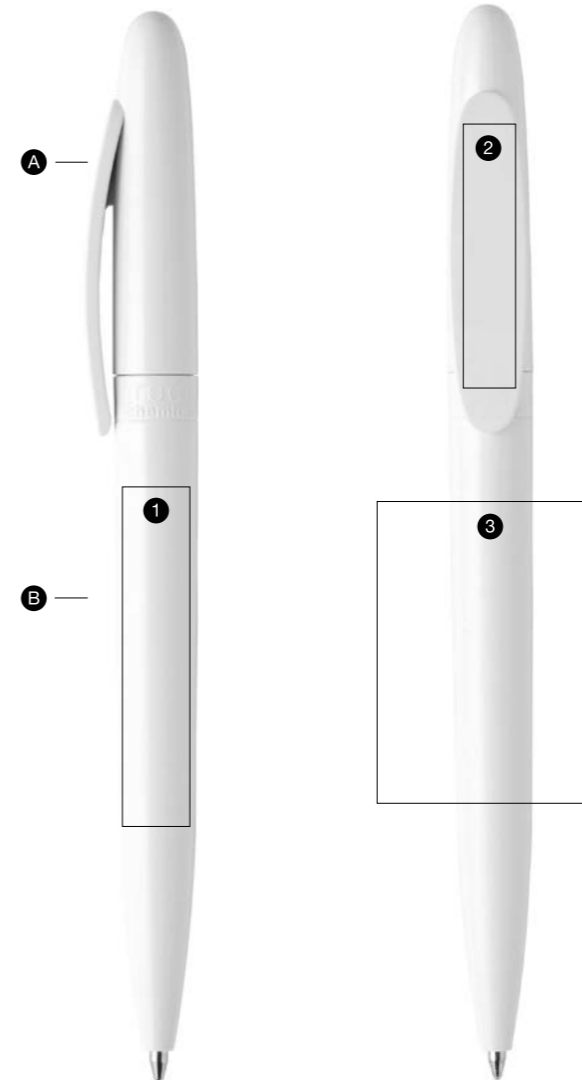

Components / Componenti

- A Cap / cappuccio
- B Barrel / fusto

Print area / Area stampabile

- 1 pad printing / tampografia
45 x 9 mm
- 2 pad printing / tampografia
35 x 7 mm
- 3 screen printing / serigrafia
40 x 30 mm

Features / Caratteristiche

twist-action / meccanismo a rotazione

made of non-toxic, highly resistant special ABS plastic certified for use in toy manufacture / realizzata in plastica ABS speciale, ad alta resistenza, atossica e certificata per l'utilizzo nei giocattoli

antibacterial / antibatterica

X20 refill, blue and black ink / refill X20, inchiostro blu e nero

available in glossy finish / disponibile con superfici lucide

Ethic



Components / Componenti

- A Small cap / tappino
- B Cap / cappuccio
- C Rings / anelli
- D Barrel / fusto
- E Tip / punta

Print area / Area stampabile

- 1 pad printing / tampografia
30 x 8 mm
- 2 screen printing / serigrafia
45 x 30 mm
- 3 pad printing / tampografia
55 x 9,5 mm

Features / Caratteristiche

twist-action / meccanismo a rotazione

made of non-toxic, highly resistant
ABS plastic / realizzata in plastica ABS,
atossica e ad alta resistenza

metal clip with chrome, gilded
or aluminium painted finish / clip in
metallo, con finitura cromata,
dorata o verniciata color alluminio

galvanic process used to chrome
or to gild ABS parts / la cromatura e
la doratura delle parti in ABS sono
ottenute con trattamento galvanico

Jumbo refill, blue and black ink / refill
Jumbo, inchiostro blu e nero

available in glossy and metallic
or aluminium painted finish / disponibile
con superfici lucide o verniciate in
colori metallizzati o alluminio

Fast Dry Gel blue and black ink available
on request /
Refill Gel Fast Dry blu e nero disponibile
su richiesta



The entire Maxema collection is available
in post-consumer recycled plastic on request /
Tutta la collezione Maxema è realizzabile
in plastica riciclata post-consumo su richiesta

Next

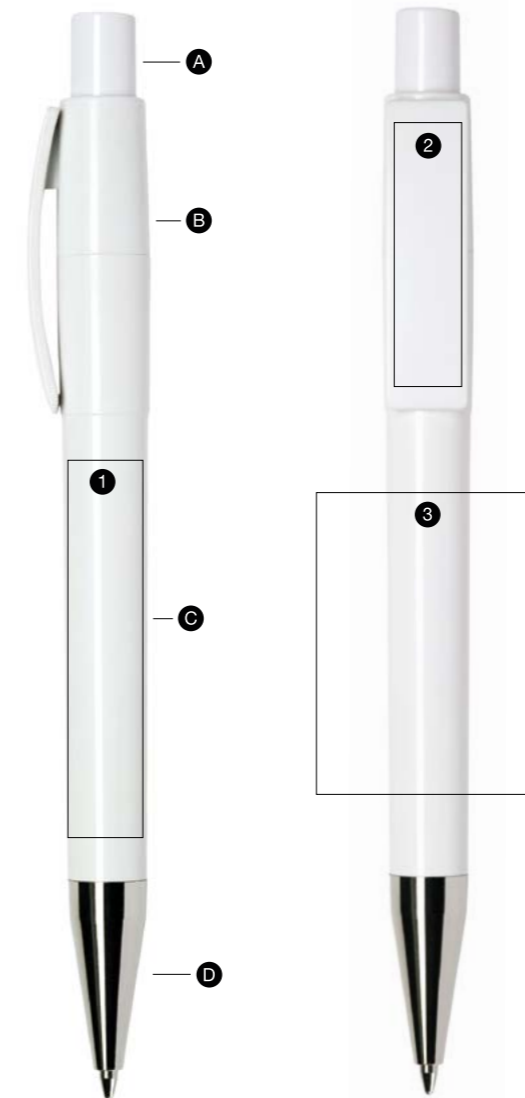

Components / Componenti

- A Push-button / tappino
- B Clip
- C Barrel / fusto
- D Tip / punta

Print area / Area stampabile

- 1 pad printing / tampografia
50 x 10 mm
- 2 pad printing / tampografia
35 x 9 mm
- 3 screen printing / serigrafia
40 x 30 mm

Features / Caratteristiche

retractable with return spring /
meccanismo a scatto, con molla
di ritorno

ventilated push-button
tappino ventilato

made of non-toxic, highly resistant
ABS plastic / realizzata in plastica ABS,
atossica e ad alta resistenza

Jumbo refill, blue and black ink /
refill Jumbo, inchiostro blu e nero

the barrel is available in glossy finish /
il fusto è disponibile con superfici lucide

galvanic process used to chrome
the ABS tip / la cromatura della punta
in ABS è ottenuta con trattamento
galvanico

Fast Dry Gel blue and black ink available
on request /
Refill Gel Fast Dry blu e nero disponibile
su richiesta



The entire Maxema collection is available
in post-consumer recycled plastic on request /
Tutta la collezione Maxema è realizzabile
in plastica riciclata post-consumo su richiesta

Pixel

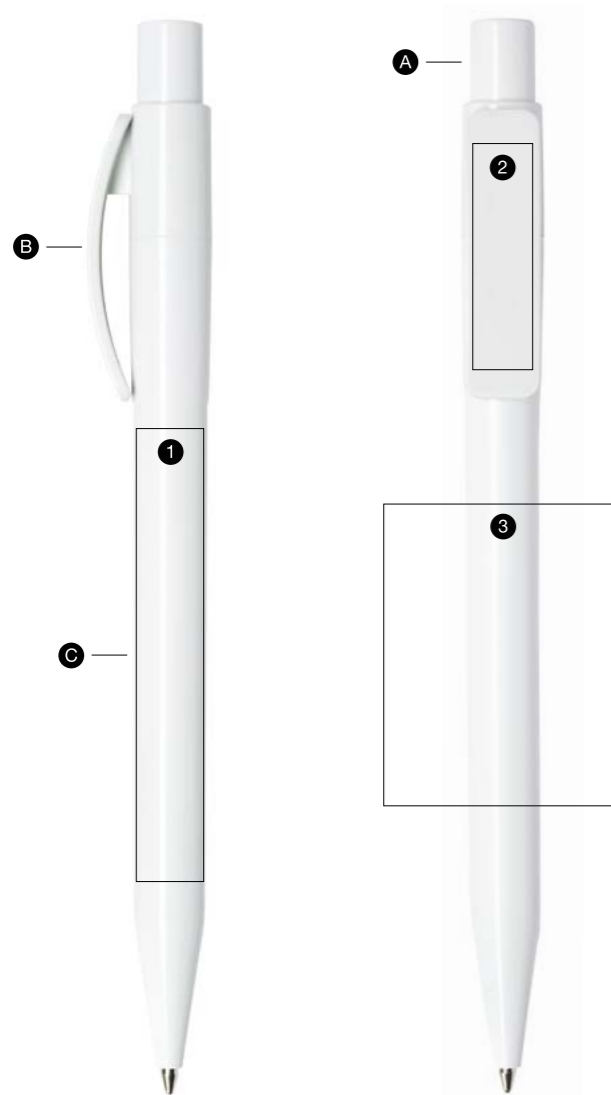

Components / Componenti

- A Push-button / tappino
- B Clip
- C Barrel / fusto

Print area / Area stampabile

- 1 pad printing / tampografia 60 x 9 mm
- 2 pad printing / tampografia 30 x 8 mm
- 3 screen printing / serigrafia 40 x 31 mm

Features / Caratteristiche

retractable / meccanismo a scatto

ventilated push-button / tappino ventilato

made of non-toxic, highly resistant ABS plastic / realizzata in plastica ABS, atossica e ad alta resistenza

X-20 refill, blue and black ink / refill X 20, inchiostro blu e nero

the barrel is available in glossy, matt or rubberised finish / il fusto è disponibile con superfici lucide, satinare o gommate

galvanic process used to chrome the ABS push-button / la cromatura del tappino in ABS è ottenuta con trattamento galvanico

rubberised barrel versions are only printable on the clip / le versioni con fusto gommato sono stampabili solo su clip

PX40 – POST-CONSUMER RECYCLED PLASTIC/ PLASTICA RICICLATA POST-CONSUMO

Small imperfections and slight colour variations are to be considered intrinsic features of the recycled material deriving from the post-consumer sector. / Piccole imperfezioni e lievi variazioni cromatiche sono da considerarsi caratteristiche intrinseche del materiale riciclato derivante dal post-consumo.

Fast Dry Gel blue and black ink available on request /
Refill Gel Fast Dry blu e nero disponibile su richiesta



The entire Maxema collection is available in post-consumer recycled plastic on request / Tutta la collezione Maxema è realizzabile in plastica riciclata post-consumo su richiesta

TAKE IT SAFE, TAKE IT EASY.

Pixel is available in white antibacterial plastic / La penna Pixel è disponibile in plastica antibatterica bianca

Bay

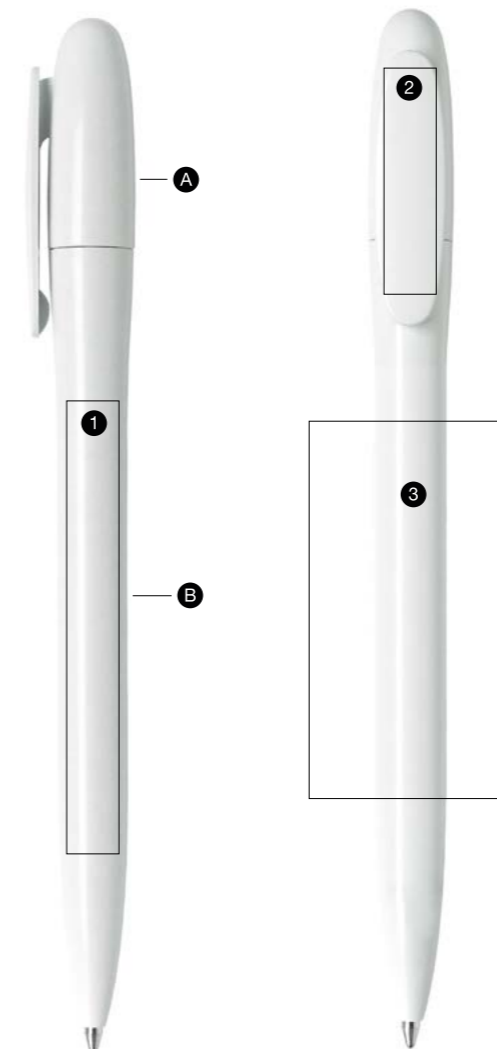

Components / Componenti

- A Cap / cappuccio
- B Barrel / fusto

Print area / Area stampabile

- 1 pad printing / tampografia 60 x 7 mm
- 2 pad printing / tampografia 30 x 7 mm
- 3 screen printing / serigrafia 50 x 28 mm

Features / Caratteristiche

twist-action / meccanismo a rotazione

made of non-toxic, highly resistant ABS plastic / realizzata in plastica ABS, atossica e ad alta resistenza

X-20 refill, blue and black ink / refill X-20, inchiostro blu e nero

available in glossy or matt finish / disponibile con superfici lucide o satinare

B500 – POST-CONSUMER RECYCLED PLASTIC/ PLASTICA RICICLATA POST-CONSUMO

Small imperfections and slight colour variations are to be considered intrinsic features of the recycled material deriving from the post-consumer sector. / Piccole imperfezioni e lievi variazioni cromatiche sono da considerarsi caratteristiche intrinseche del materiale riciclato derivante dal post-consumo.

Fast Dry Gel blue and black ink available on request /
Refill Gel Fast Dry blu e nero disponibile su richiesta



The entire Maxema collection is available in post-consumer recycled plastic on request / Tutta la collezione Maxema è realizzabile in plastica riciclata post-consumo su richiesta

TAKE IT SAFE, TAKE IT EASY.

Bay is available in white antibacterial plastic / La penna Bay è disponibile in plastica antibatterica bianca

Packaging

p. 308

Sales support *Supporti di vendita*

p. 314

Inks and refills *Inchiostri e refill*

p. 322

Packaging

MY CASE



Pad printing / tampografia

- ① 4,2 x 16,6 cm
- ② 4,3 x 14,8 cm

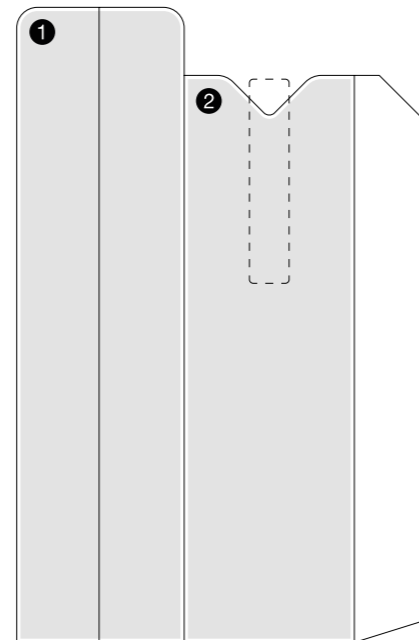

universal single pen case in Fedrigoni Ultra Black 280 g/m² card, personalisable with pad printing

size: 4,4 x 16,8 cm

—
astuccio universale per penna singola in cartoncino Fedrigoni Ultra Black 280 gr/m², personalizzabile con stampa tampografica

dimensioni: 4,4 x 16,8 cm

MY CASE — KIND



universal single pen case in Fedrigoni FSC-certified Arena Extra White 300 g/m², personalisable with pad printing

size: 4,4 x 16,8 cm



Back / retro EN



Back / retro IT

—
astuccio universale per penna singola in cartoncino Fedrigoni Arena Extra White 300 gr/m², certificato FSC, personalizzabile con stampa tampografica

dimensioni: 4,4 x 16,8 cm

Extra imprint (on demand) / Personalizzazione extra (su richiesta)

KIND – RECYCLED PET



①

Back / retro
EN

②

Back / retro
IT

The sustainability choice needs to be communicated. So personalise your Kind with a message about this pen's origin.

—
Una scelta sostenibile va comunicata. Personalizza la tua Kind con un messaggio che racconta l'identità di questa penna.

Pad printing / tampografia

① 50 x 3 mm

② 50 x 3 mm

Packaging

MY BOX



Pad printing / tampografia

① 14,8 x 2 cm

② 14,9 x 2 cm

③ 14,8 x 2 cm

④ 14,8 x 2 cm

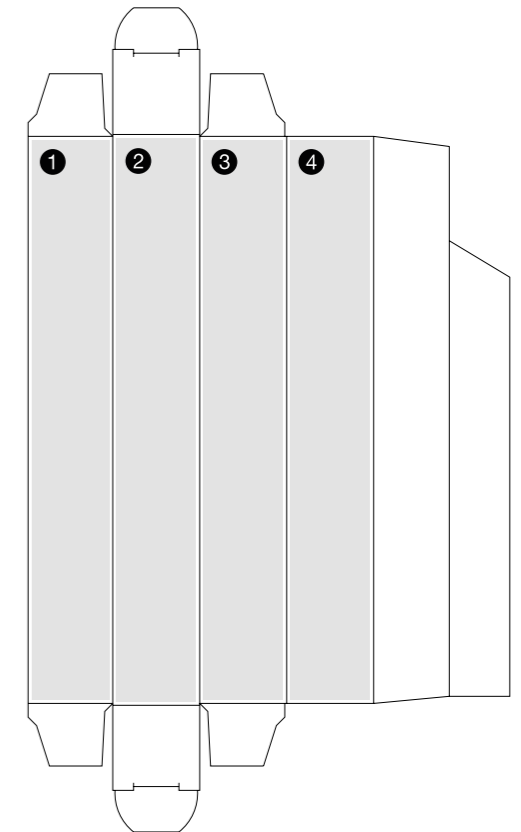

universal reclosable single pen case in Fedrigoni Ultra Black 280 g/m² card, personalisable with pad printing

size: 2,3 x 15,1 x 2,3 cm

—
astuccio universale richiudibile per penna singola in cartoncino Fedrigoni Ultra Black 280 gr/m², personalizzabile con stampa tampografica

dimensioni: 2,3 x 15,1 x 2,3 cm

Packaging

MY BOX — RECYCLED



Kraft



Clay



Ardesia



Anche i nostri astucci si prendono cura dell'ambiente.

Even our cases look after the environment.

Pad printing / tampografia

- ① 14,8 x 2 cm
- ② 14,9 x 2 cm
- ③ 14,8 x 2 cm
- ④ 14,8 x 2 cm

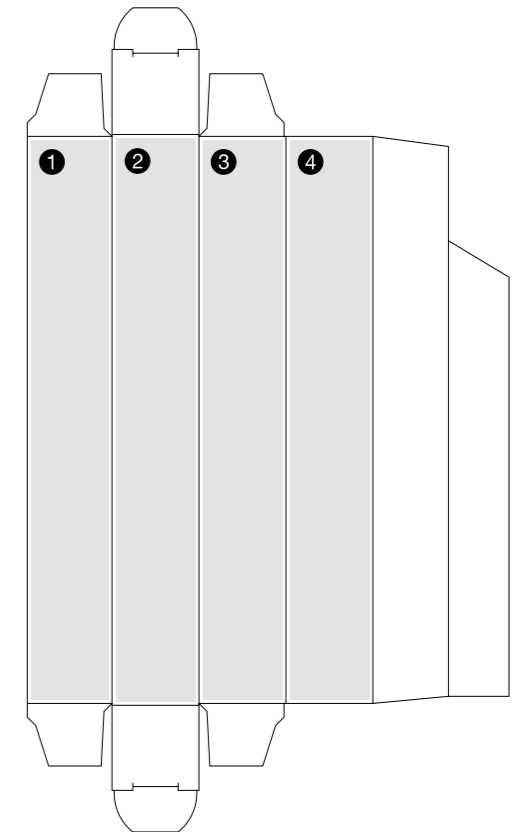

universal reclosable single pen case in Fedrigoni recycled paper Kraft, Clay and Ardesia 250 g/m² card, personalisable with pad printing

size: 2,3 x 15,1 x 2,3 cm

—
astuccio universale richiudibile per penna singola in cartoncino Fedrigoni riciclato Kraft, Clay e Ardesia 250 g/m², personalizzabile con stampa tampografica

dimensioni: 2,3 x 15,1 x 2,3 cm

Minikit

8 R-PET PENS



Contains 8 printed KIND pens in R-PET plastic, in assorted colours and finishes.

size: 24,3 x 20 cm (closed format)

Contiene 8 penne KIND in plastica R-PET personalizzate, in colori e finiture assortite.

dimensioni: 24,3 x 20 cm (formato chiuso)

Minikit

6 POST-CONSUMER RECYCLED PENS

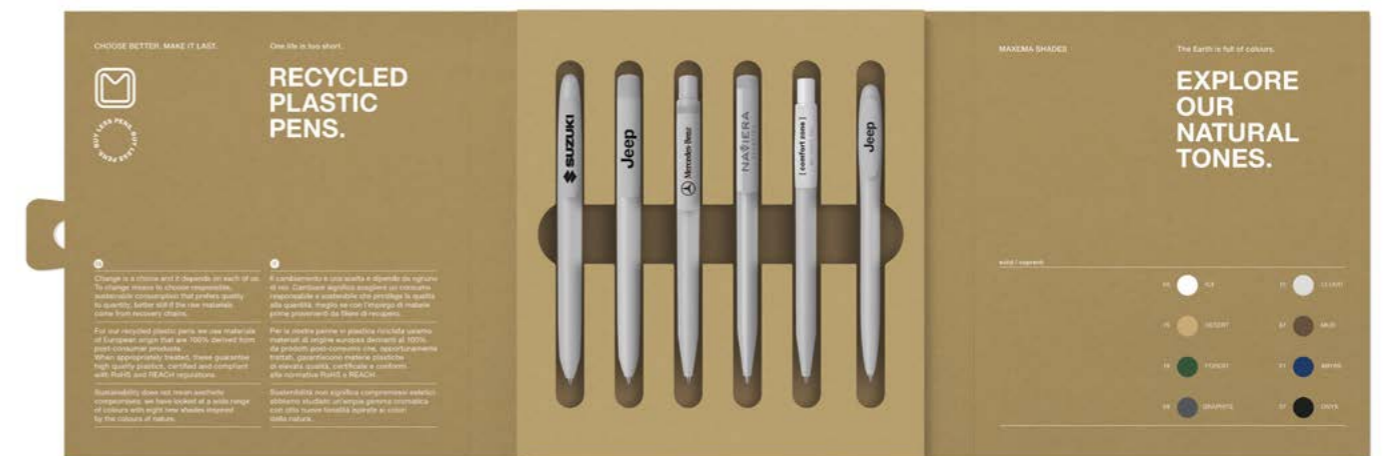

L'attenzione verso il nostro pianeta si esprime anche attraverso la scelta di un packaging sostenibile. Un minikit certificato FSC composto da cellulosa, fibre di riciclo certificate e fibre di cotone. Rispetto dell'ambiente e sostenibilità garantite da un efficace strumento espositivo.

contains 6 different recycled plastic models: Icon Pure, Flow Pure, Dot, Zink, Pixel and Bay

size: 19 x 19,8 cm (closed format)

contiene 6 diversi modelli di penne in plastica riciclata: Icon Pure, Flow Pure, Dot, Zink, Pixel e Bay

dimensioni: 19 x 19,8 cm (formato chiuso)

Minikit

8 POST-CONSUMER RECYCLED PENS



Care for our planet can also be expressed through the choice of sustainable packaging. An FSC-certified minikit made of cellulose, certified recycled fibres and cotton fibres. Respect for the environment and sustainability guaranteed by an effective display tool.

contains 8 pens of one model, in all available colours
 size: 24,3 x 20 cm (closed format)
 contiene 8 penne di un modello, in tutti i colori disponibili
 dimensioni: 24,3 x 20 cm (formato chiuso)

Minikit

MOOD METAL



Metal elegance in 3 different finishes and clip available in 23 shades.

L'eleganza del metallo in 3 diverse finiture e clip disponibile in 23 colorazioni.

3 Mood Metal in chrome, titanium grey and gold finish
 size: 10,2 x 19 cm (closed format)
 3 Mood Metal nelle finiture: cromato, grigio titanio e oro
 dimensioni: 10,2 x 19 cm (formato chiuso)

Minikit

ANTIBACTERIAL



Monochromatic presentation of the Antibacterial collection: white has always been a symbol of safety and protection.

Presentazione monocromatica della collezione Antibacterial: il bianco è da sempre simbolo di sicurezza e protezione.

GENERAL / GENERICO



The essential selection of our best sellers: Minikits are valuable tools to display, consult and collect.

La selezione essenziale dei nostri best seller: i Minikit sono strumenti preziosi da esporre, consultare, collezionare.

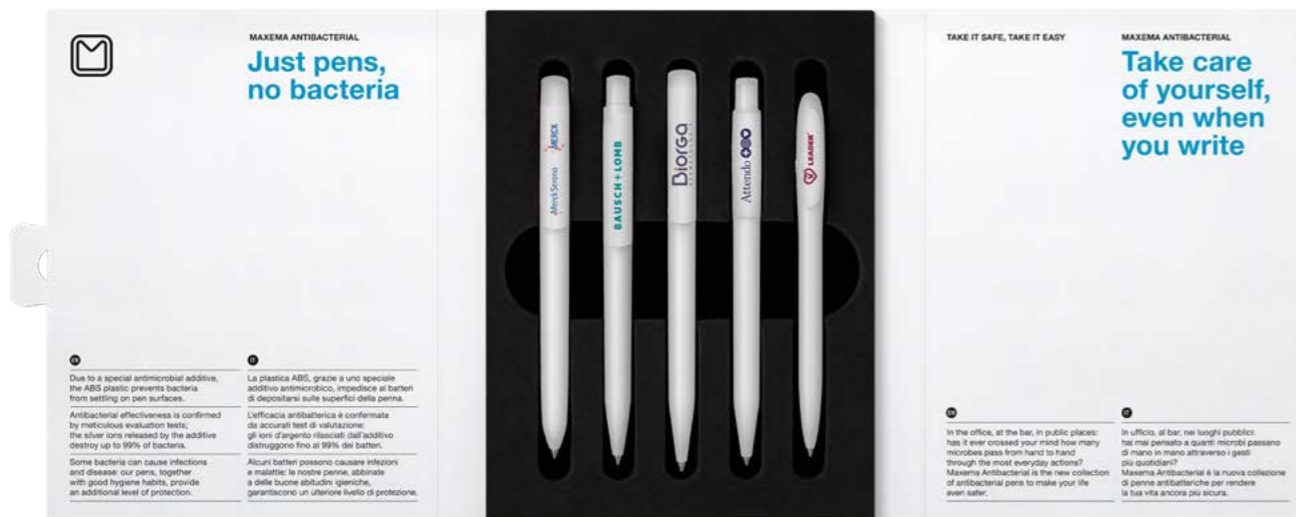

5 antibacterial printed pens in white colour

size: 10,2 x 19 cm (closed format)

—
5 penne antibatteriche bianche

dimensioni: 10,2 x 19 cm (formato chiuso)

5 printed pens in assorted colours of the most representative models

size: 14,7 x 19 cm (closed format)

—
5 penne stampate in colori assortiti dei modelli più rappresentativi

dimensioni: 14,7 x 19 cm (formato chiuso)

Kit and box sets / Kit e raccoglitori

KIT



20 printed pens in assorted colours of the most representative models

size: 25 x 34 cm (closed format)

—
20 penne stampate in colori assortiti dei modelli più rappresentativi

dimensioni: 25 x 34 cm (formato chiuso)

BOX SETS / RACCOGLITORI

The Kits are available in 1, 2 or 3 unit box sets / i Kit sono disponibili in raccoglitori da 1, 2 o 3

- ① 28 x 33 x 3 cm
- ② 28 x 33 x 5,5 cm
- ③ 28 x 33 x 8 cm

MODEL KIT / KIT MODELLO

20 printed pens in assorted colours of a single model size: 25 x 34 cm (closed format)

—
20 penne stampate in colori assortiti di un unico modello dimensioni: 25 x 34 cm (formato chiuso)

—
the Model Kit is available for / il Kit Modello è disponibile per:
Kind, Icon Pure, Mood Metal, Dot Antibacterial, Mood, Flow Pure, Flow, Dot, Zink, View, Tag, Icon, Icon Green, Tag Green, Ethic, Pixel, Next, Bay.



On request we can prepare customised sets of samples containing specific versions and colours of pens.

—
Su richiesta possiamo realizzare campionari personalizzati con penne di specifiche versioni e colori.

Inks and refills / *Inchiostri e refill*

INKS / INCHIOSTRI



blue
blu



black
nero

X-20



tungsten carbide ball Ø 1 mm, length 107 mm, for up to 2000 meters of writing
sfera in carburo di tungsteno Ø 1 mm, lunghezza 107 mm, fino a 2000 metri di scrittura

JUMBO



tungsten carbide ball Ø 1 mm, length 107 mm, for up to 2500 meters of writing
sfera in carburo di tungsteno Ø 1 mm, lunghezza 107 mm, fino a 2500 metri di scrittura

The refill's barrel is made of polypropilene, the tip is made of nickel-plated brass.

The ink is Dokumental.

All Dokumental inks comply with European REACH and American TSCA standards.

Il tubetto del refill è in polipropilene, la punta è in ottone nichelato.

L'inchiostro, è Dokumental.

Tutti gli inchiostri Dokumental sono conformi alla normativa europea REACH e americana TSCA.

RT90 PARKER TYPE BLACK TUBE, BRANDED WITH MAXEMA LOGO ON DEMAND

RT90 TIPO PARKER TUBO NERO CON LOGO MAXEMA SU RICHIESTA



tungsten carbide ball Ø 1 mm, length 98 mm, for up to 4000 meters of writing
sfera in carburo di tungsteno Ø 1 mm, lunghezza 98 mm, fino a 4000 metri di scrittura

The refill's barrel is made of polypropilene, the tip is made of nickel-silver brass.

The ink is Dokumental.

All Dokumental inks comply with European REACH and American TSCA standards.

Il tubetto del refill è in polipropilene, la punta è in nichel-silver.

L'inchiostro è Dokumental.

Tutti gli inchiostri Dokumental sono conformi alla normativa europea REACH e americana TSCA.

RT90 PARKER TYPE TUBO BIANCO ON DEMAND

RT90 TIPO PARKER TUBO BIANCO SU RICHIESTA



tungsten carbide ball Ø 1 mm, length 98 mm, for up to 4000 meters of writing
sfera in carburo di tungsteno Ø 1 mm, lunghezza 98 mm, fino a 4000 metri di scrittura

GEL FAST DRY ON DEMAND / SU RICHIESTA



titanium carbide ball (SS, TC), Ø 0.7 mm, tip in stainless steel, length 98 mm, up to 700 meters of writing

sfera in carburo di titanio (SS, TC) Ø 0,7 mm, punta in acciaio inox, lunghezza 98 mm, fino a 700 metri di scrittura

Water-based, non-toxic gel ink, produced in Italy and compliant with European REACH and American TSCA standards. The refill's barrel is made of polypropilene.

Inchiostro gel a base acqua, atossico e prodotto in Italia, conforme alla normativa europea REACH e americana TSCA. Il tubetto del refill è in polipropilene.

**all rights reserved maxema srl
tutti i diritti riservati maxema srl**

The brands mentioned in this catalogue are the exclusive property of the respective owners. They are used for purely illustrative purposes and cannot be the object of any buying and selling transactions, under any circumstances.

I marchi menzionati in questo catalogo sono di proprietà esclusiva dei rispettivi proprietari. L'utilizzo dei suddetti marchi è a puro titolo esemplificativo e non potrà mai, in alcun caso, essere oggetto di trattative commerciali.

art direction and graphic design
undesign.it

still life
infinistudio.com

editing
elena ambrosio
sara zampedri

PUSH-BUTTON / TAPPINO



BARREL / FUSTO

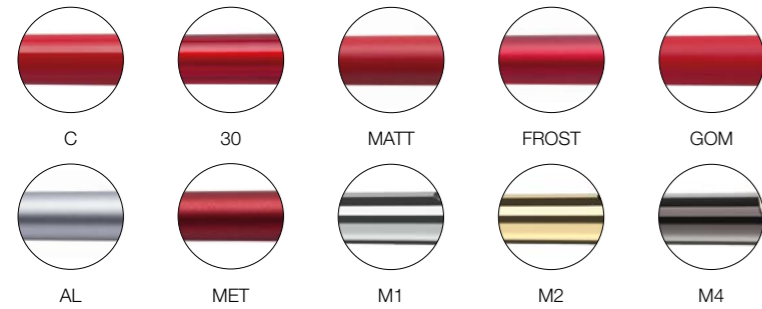

CLIP

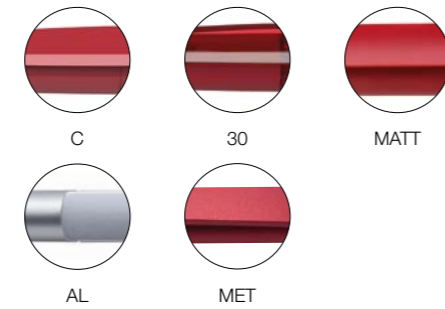

CAP / CAPPUCCIO

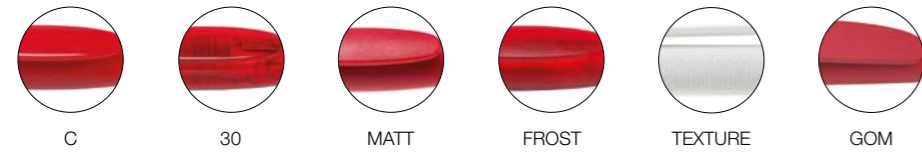

TIP / PUNTA

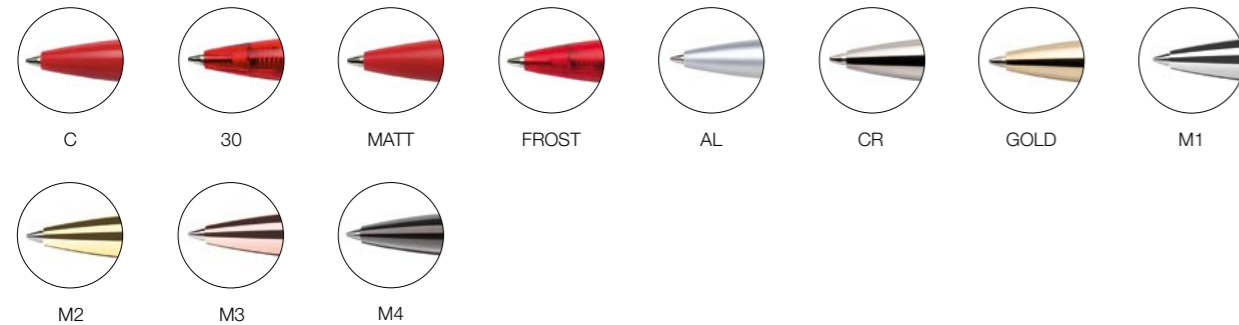

PLUG / TASSELLO

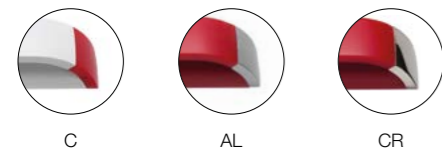

RINGS / ANELLI



Our colour chart is shown below with the Pantone codes closest to those of our Palette. Matches are approximate.

In questa tabella sono riportati i nostri colori con i codici Pantone che più si avvicinano a quelli della nostra Palette. La corrispondenza è puramente indicativa.

solid / coprenti

01	white / bianco	
70	cream / crema	pant 7499
03	yellow / giallo	pant 120
18	orange / arancio	pant 1505
15	red / rosso	pant 187
74	burgundy / bordeaux	pant 195
60	pink / rosa	pant 1905
61	magenta	pant 213
71	light violet / viola chiaro	pant 270
25	dark violet / viola scuro	pant violet
72	leather / cuoio	pant 7571
73	brown / marrone	pant 7582
79	lime	pant 381
09	green / verde	pant 348
75	dark green / verde scuro	pant 3435
26	aquamarine / acquamarina	pant 3262
27	ocean green / ottanio	pant 321
64	pastel blue / azzurro pastello	pant 283
77	cyan / ciano	pant 2995
12	light blue / azzurro	pant 285
22	blue / blu	pant 288
05	grey / grigio	pant cool gray 4
04	black / nero	pant black 6

trasparent / trasparenti

39	neutral / neutro	
52	yellow / giallo	pant 116
53	orange / arancio	pant 1505
45	red / rosso	pant 200
59	pink / rosa	pant 1905
41	magenta	pant 213
31	lilac / lilla	pant 2705
51	violet / viola	pant 2425
55	dark violet / viola scuro	pant violet
37	amber / ambra	pant 7571
38	brown / marrone	pant 7582
78	lime	pant 381
49	green / verde	pant 348
47	aquamarine / acquamarina	pant 3272
34	light blue / azzurro	pant 283
67	cyan / ciano	pant 306
44	blue / blu	pant 286
30	light grey / grigio chiaro	pant cool gray 6
40	grey / grigio	pant 437
32	pure grey / grigio puro	pant 431
50	dark grey / grigio scuro	pant 446

solid Icon green and Tag green / Icon green e Tag green coprenti

01	white / bianco	
70	cream / crema	pant 7499
42	yellow / giallo	pant 012
43	orange / arancio	pant 151
35	red / rosso	pant 179
13	brown / marrone	pant 7532
29	green / verde	pant 7741
65	dark green / verde scuro	pant 343
77	cyan / ciano	pant 2995
54	blue / blu	pant 7685
04	black / nero	pant black 6

POST-CONSUMER RECYCLED PLASTIC PENS
PENNE IN PLASTICA RICICLATA POST-CONSUMO

solid / coprenti

06	ice	
10	cloud	pant cool gray 1 C
76	desert	pant 466 C
87	mud	pant 7532 C
19	forest	pant 7735 C
21	abyss	pant 654 C
58	graphite	pant 425 C
07	onyx	

Pantone colours are available on demand. Please contact us to find out the minimum order quantity for each model.
I colori Pantone sono disponibili su richiesta, contattateci per conoscere i quantitativi minimi per ogni modello.

△ POST-CONSUMER RECYCLED PLASTIC PENS / PENNE IN PLASTICA RICICLATA POST-CONSUMO — solid / coprenti

- | | | | | | |
|-------------|----------|-----------|--------|-----------|----------|
| 06 ice | 10 cloud | 76 desert | 87 mud | 19 forest | 21 abyss |
| 58 graphite | 07 onyx | | | | |

solid / coprenti

- | | | | | | |
|-----------------|-----------------------|------------------------------|----------------------------|------------------------|---------------------------------|
| 01 white bianco | 70 cream crema | 03 yellow giallo | 18 orange arancio | 15 red rosso | 74 burgundy bordeaux |
| 60 pink rosa | 61 magenta magenta | 71 light violet viola chiaro | 25 dark violet viola scuro | 72 leather cuoio | 73 brown marrone |
| 79 lime lime | 09 green verde | 75 verde scuro dark green | 26 aquamarine acquamarina | 27 octan green ottanio | 64 pastel blue azzurro pastello |
| 77 cyan ciano | 12 light blue azzurro | 22 blue blu | 05 grey grigio | 04 black nero | |

transparent / trasparenti

- | | | | | | |
|-------------------|---------------------------|----------------------------|----------------|------------------|-----------------------------|
| 39 neutral neutro | 52 yellow giallo | 53 orange arancio | 45 red rosso | 59 pink rosa | 41 magenta magenta |
| 31 lilac lilla | 51 violet viola | 55 dark violet viola scuro | 37 amber ambra | 38 brown marrone | 78 lime lime |
| 49 green verde | 47 aquamarine acquamarina | 34 light blue azzurro | 67 cyan ciano | 44 blue blu | 30 light grey grigio chiaro |
| 40 grey grigio | 50 dark grey grigio scuro | 32 pure grey grigio puro* | | | |

**(Available only for R-PET pens / disponibile solo per le penne in R-PET)*

solid Icon green and Tag green / Icon green e Tag green coprenti

- | | | | | | |
|-----------------|---------------------------|------------------|-------------------|---------------|------------------|
| 01 white bianco | 70 cream crema | 42 yellow giallo | 43 orange arancio | 35 red rosso | 13 brown marrone |
| 29 green verde | 65 dark green verde scuro | 77 cyan ciano | 54 blue blu | 04 black nero | |

metallic paintings / vernici metallizzate

- | | | | | | |
|----------------|------------------|----------------|-------------------------|---------------------|----------------------------|
| 91 pearl perla | 92 gold oro | 83 copper rame | 85 red rosso | 81 violet viola | 82 dark violet viola scuro |
| 89 green verde | 94 aviation avio | 95 blue blu | 96 anthracite antracite | aluminium alluminio | |

solid fluo / fluo coprenti

- | | | | | |
|------------------|-------------------|----------------------------|-------------------|----------------|
| 02 yellow giallo | 17 orange arancio | 14 coral red rosso corallo | 56 fuchsia fucsia | 08 green verde |
|------------------|-------------------|----------------------------|-------------------|----------------|

transparent fluo / fluo trasparenti

- | | | | | |
|------------------|-------------------|----------------------------|-------------------|----------------|
| 20 yellow giallo | 33 orange arancio | 24 coral red rosso corallo | 46 fuchsia fucsia | 48 green verde |
|------------------|-------------------|----------------------------|-------------------|----------------|

galvanic process / trattamento galvanico

- | | |
|----------------|-------------|
| chrome cromato | gold dorato |
|----------------|-------------|

metal finishes / finiture metallo

- | | | | |
|----------|----------------|--------------------|------------------------------|
| gold oro | chrome cromato | rose gold oro rosa | titanium gray grigio titanio |
|----------|----------------|--------------------|------------------------------|



Made
in Italy



Prodotto
in Italia



Fabriqué
en Italie



Fabricado
en Italia



maxema.com